

Quick-Fit[®] and Flanged Ducting

Product Reference

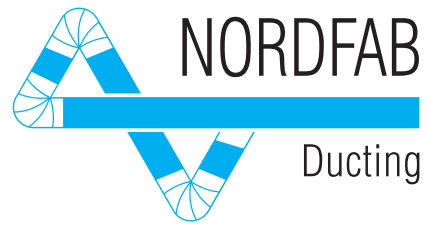

All the Ducting Components You Need for Your Dust
Collection / Process Ventilation System



**Made in
the USA**



What Ducting Is Right For Your Application?

When selecting ducting for your dust, mist, or fume collection application, you must choose:

- type of connection (end type)
- material and strength (metal gauge),
- size

Connection Type (End Type)

Nordfab originated the modular Quick-Fit® (QF®) clamp together duct system in the 1990s to help users reduce installation time (users just wrap a clamp around two connecting pieces and snap the clamp closed) and installation costs and to provide a re-useable product that can be easily cleaned or reconfigured during facility reorganizations or machinery moves. Users have found that Quick-Fit is ideal for most dust, mist and fume collection applications; it has been applied in a wide variety of industrial settings.

In addition to the QF clamp together end type, Nordfab provides a number of other end types, including flanged, so that users can incorporate Quick-Fit into other systems and to ensure we can provide duct all the way from your collector or cyclone to the last machine port. We also provide components to allow users to incorporate clamp together duct into existing ductwork.

Material and Gauge

Quick-Fit is available in either galvanized steel or 304 Stainless Steel (SS) in a range of gauges so users can select the gauge appropriate to suit the rigor of the application. 316 Stainless Steel or carbon steel construction is optional when required. Nordfab is the only manufacturer of clamp-together ducting which provides third-party testing regarding duct strength.

Duct Sizes

Nordfab provides ducting in sizes from 3" to 72" diameter.

Nordfab provides a variety of resources to assist you in sizing your ductwork, including the sizing information in this catalog, complimentary CAD and SketchUp software, and/or installation design assistance from our Authorized Dealers.

The World's Fastest Ducting

Nordfab's Quick-Fit® (QF®) clamp together duct is "The World's Fastest Ducting" during every phase of your dust collection installation. From the time you first need design or quotation assistance, through delivery and installation, to after sales service and replacement parts, Nordfab lives up to being "The World's Fastest Ducting".

- QF clamps together in seconds without welds, bolts, screws, flanges, special tools, precise measurements or specialized skills. It cuts installation time – and duct-related downtime – by more than 45% over traditional ductwork.
- Our nationwide distribution network understands the urgency of your requests and has the tools and training to design and quote a system very quickly.
- Nordfab ships most QF orders in four days or less. And if you have an emergency, we can often get stock or galvanized standard parts shipped on the day you call.
- Once your QF ducting is installed, you can quickly and easily take it apart for cleaning or to reconfigure for any floor plan changes.



QF clamps together in seconds without welds, bolts, screws, flanges, special tools, precise measurements or specialized skills.

Nordfab can provide the right duct product for your requirement:

- Easy to use clamp together (QF) duct in sizes up to 24"
- Galvanized, SS, carbon steel
- Gauges from 22 to 10
- Sizes up to 72"
- Products for special applications
- Custom fittings to meet your need

Contact us to learn more

Who Is Nordfab?

In the US, Nordfab currently owns and operates two office and manufacturing facilities in Thomasville, North Carolina — a 142,000 ft² facility for manufacturing QF products and a 35,000 ft² facility for manufacturing heavier gauge products. More than 150 production, sales, and customer support employees work at our facilities. No direct competitor in the industry matches Nordfab's investment in qualified employees, R&D or production technology.

Nordfab Americas was incorporated in 1979.

The Nordfab brand was originally introduced in 1973 so we are celebrating our brand's 50th anniversary in 2023.



Nordfab is ISO 9001:2015 and ISO 14001:2015 registered, ensuring our dependability, quality, service, delivery, and minimum impact on the environment.

Nordfab is a global manufacturer with sales and production facilities in Europe (Scandinavia and the United Kingdom) and Asia as well as the USA.



Ordering

Nordfab products may be ordered by product description:

Product name, material, size(s) and end type(s).
When gauge is not specified, the standard gauge will be supplied.

Examples:

Pipe Galv 14QF

Branch Galv 20QF 18QF 12QF

Reducer 304SS 12AFL 8AFL

(In above examples, standard gauge will be supplied as no gauge is specified. In the example below, heavier duty 14gauge is specified.)

Elbow Galv 14ga 8QF 45Deg R=1.5

End Types

If you do not specify an end type, we will supply as standard: QF ends for duct in sizes from 3" to 24" and Angle Flange ends for sizes above 24".

QF: Quick-Fit® rolled ends for quick connection to other QF components using the QF Clamp.

AFL: Industry-standard Angle Ring.

Nordfab standard is Angle Flange (AFL) attached loosely and retained in place using a vanstone lip. Upon customer request, the flange can be solid welded to product or provided loose (separate) with a NOFIT end. Flanges to be welded will require clocked location.

FFL: Flat Flange. Provided when custom flange is required (for options such as custom hole pattern). Same connections as ANGFL.

RAWFLEX: Raised dimple to retain flexible hose.

NOFIT: No Fitting. A raw end with standard dimensions based on product size.

RAWOD: Raw end without fitting. End dimension based on customer specified Outside Diameter.

RAWID: Raw end without fitting. End dimension based on customer specified Inside Diameter.

(See illustrated examples of End Types, page 34)

End Type	Abbreviation
Quick-Fit	QF
No Fit	NF
Raw ID	RI
Raw OD	RO
Rawflex	RF
Angle Flange	AFL
Flat Flange	FFL
Vanstone	VS

Table of Contents

Description	Page	Description	Page
Air Volume Chart	58	Gripple Hanger	42
Angle Flange	12	Hose Adapter	26
Angle Flange Adapter	24	Hose Clamp	34
Angle Flange Gasket	13	In-Cut	21
◇ Ball Joint	50	In-line Spark Trap	55
Barrel Hood	36	Installation Tips	59
Bell Mouth Hood	36	Jet Cap	47
Blast Gate Automatic NFES	31	Machine Adapter	25
Blast Gate Automatic SD	32	Manifold Specification	39
Blast Gate Manual	29	No-Loss Stackhead	46
Blast Gate NFMES	30	QFS Molded Gasket	56
Bleed-In Valve	50	QFS O-ring	56
Branch	17	Oil Mist Recycler	57
Bridge Clamp (Hose)	34	Nordfab Sealed Duct System (QFS)	56-57
Butterfly Valve	51	O-Ring	10
Canopy Hood	37	Pipe	9
Clamp Hanger	43	Pipe Hanger	42
Clamp w/ Pin - Nitrile Seal	8	Pipe Hanger HJ	43
Clamp w/ Pin - Silicone Seal	8	Quick-Fit Sleeve (formerly Adj. Nipple)	10
Clamp w/ Pin - ePTFE Seal	8	Quick-Fit Sleeve Assembly	11
Conditions of Sale	63	Radial Arm Saw Hood	37
Damper, Back Draft	49	Reducer	23
◇ Diverter Valve Automatic	40	Reed Switch Assembly 1.06	32
◇ Diverter Valve Manual	40	Reed Switch Assembly 2.50	41
◇ Diverter Valve SD Automatic	41	Return Goods Chart	62
◇ Diverter Valve SD Manual	41	Rigid Flex Steel Hose	35
Double Branch	19	Router Hood	38
Drain Back for Hose	57	Router Hood w/ Magnet	38
Drawing Service	39	Rubber Hose	33
Drop Out Box	53	Shipping Details	61
Elbow	14-15	Silencer	48
Elbow Flanged	14-15	Sizing a Pipe System	58
Elbow Tubed	16	Sliding Access Panel	52
Elbow Tubed Long Radius	16	Static Dissipative Urethane Hose	33
Elbow Flanged Long Radius	15	Strut Hanger	42
Elbows Long Radius	15	Suction Hood	38
End Cap	28	Suction Nozzle Assembly	48
End Cap with Bird Screen	28	Take-Off Sheet	60
End Plate	28	Tap-In	22
Flanged Pipe	9	Tee Branch	20
Flashing - Roof	44	Temperature Rating Chart	7
Flashing - Roof Skirt	45	Transition Rectangular to Round	27
Flashing - Wall	44	Ultra Flex Steel Hose	35
Flex Hose & Duct End Types	34	◇ Vibration Isolator	54
Floor Sweep	53	Viewing Spool	52
General Engineering Specification	5-6	Weather Cap	45
		Y-Branch	18

◇ Long Lead Items



Made in the USA

Type	Description	Page	Type	Description	Page	Type	Description	Page	Type	Description	Page
Pipe & Clamps			Adapters			Hoods			Accessories		
	QF Clamp	8		Reducer	23		Barrel Hood	36		Weather Cap	45
	QF Pipe & Flanged Pipe	9		Angle Flange Adapter	24		Bell Mouth Hood	36		No-Loss Stackhead	46
	Quick-Fit Sleeve & O-Ring	10		Machine Adapter	25		Canopy Hood	37		Jet Cap	47
	Quick-Fit Sleeve Assembly	11		Hose Adapter	26		Radial Arm Saw Hood	37		Silencer	48
	Angle Flange	12		Transition Rectangular to Round	27		Router Hood & Router Hood w/ Magnet	38		Suction Nozzle Assembly	48
	Angle Flange Gasket	13		End Cap & End Cap with Bird Screen	28		Suction Hood	38		In Line Back Draft Damper	49
Elbows				End Plate	28	Diverter Valves				Ball Joint	50
	QF Elbow & Flanged Elbow	14	Blast Gates				Diverter Valve Manual	40		Bleed-In Valve	50
	Elbows Long Radius	15		Blast Gate Manual	29		Diverter Valve Automatic	40		Butterfly Valve	51
	Elbows Tubed	16		Blast Gate NFMES	30		SD Diverter Valve - Manual & Automatic	41		Viewing Spool	52
	Elbow Tubed Long Radius	16		Blast Gate Automatic NFES	31	Hangers & Installation				Sliding Access Panel	52
Branches				Blast Gate Automatic SD	32		Gripple Hanger	42		Floor Sweep	53
	Branch	17	Hoses & Clamps				Strut Hanger	42		Drop Out Box	53
	Y-Branch	18		Rubber Hose, Black & Clear	33		Pipe Hanger	42		Vibration Isolator	54
	Double Branch	19		Static Dissipative Urethane Hose	33		Pipe Hanger HJ	43		In-line Spark Trap	55
	Tee Branch	20		Hose Clamp	34		Clamp Hanger	43	Special Applications		
	In-Cut	21		Bridge Clamp (Hose)	34		Wall Flashing & Roof Flashing	44		QFS Molded Gasket / QFS O-Ring	56
	Tap-In	22		Rigid Flex Steel & Ultra Flex Steel Hose	35		Roof Skirt	45		Oil Mist Recycler / Drain Back for Hose	57

Nordfab Ducting General Specifications

Structural Integrity and General Engineering Specification for Quick-Fit Ducting

Applications

Nordfab's laser welded seam Quick-Fit® Ducting System has been used in many different industrial applications, and under various negative static pressures.

The typical design range we see in our applications range from -2" wg to -28" wg; however, we have some systems operating at vacuums of -32" wg to -42" wg under normal operating parameters.

Our pipe comes in 5' lengths with a rolled lip on each end, thus providing reinforcement every 5', which presents a sound structural design that should be as strong or stronger than any pipe in its class according to SMACNA guidelines and regulations.

Structural Integrity

All fit-together ducting systems allow for some degree of leakage where they are joined. QF® ducting is no exception and is not sold as an airtight system.

In comparison to other ducting typically used in fit-together / clamp-together systems, Nordfab's QF duct pipe has fully welded, leak-tight laser or plasma welded seams. Spiral and other ducting with lockform seams are *not* fully welded at the pipe seams and can be expected to have higher leakage rates than QF duct.

Application of sealants to the individual rolled ends can also enhance the tightness of the system. However, the QF system is sold as a quick way of installing and modifying ductwork while at the same time retaining the usability of each component. In short, QF is designed with the capability to be taken apart, re-assembled, stored or moved. Completely eliminating the possibility for leakage jeopardizes the inherent benefits of the duct.

While Nordfab is currently unaware of any method of evaluating dust collection piping alone, the following data is presented using the criteria for all duct, including HVAC. This data is presented only for the purpose of indicating acceptability of the QF in dust/fume removal in a negative pressure situation and should not be confused with the ducting that uses tape or gaskets as sealant in the positive conveyance of air.

Leakage Rate

Standard QF ductwork is designed to provide tight sealing and efficient airflow under negative pressures. To that end, we are providing the following information for piping situations where fan sizing is of extreme importance. The following

data was obtained using standard components and was performed in accordance with the SMACNA, "HVAC AIR DUCT LEAKAGE TEST MANUAL". The information gives the leakage rate per joint of duct at various pressures. To utilize the chart, count the number of clamps (this equals the number of pieces) per size and multiply by the number given beside the corresponding diameter and under the applicable pressure. These numbers assume that the product is correctly installed, free of dents in the joining ends, and that the gasket is in place. Special gasket material and sealants will increase the sealing capabilities.

Leakage Rate In CFM Per QF Joint

Ø in.	3 WG	5 WG	7.5 WG	10 WG	15 WG	20 WG	25 WG	30 WG
4	0.20	0.25	0.30	0.30	0.35	0.50	0.60	0.80
5	0.20	0.25	0.30	0.30	0.35	0.50	0.60	0.80
6	0.20	0.25	0.30	0.30	0.35	0.50	0.60	0.80
7	0.20	0.25	0.30	0.30	0.35	0.50	0.60	0.80
8	0.20	0.25	0.30	0.30	0.35	0.50	0.60	0.80
9	0.20	0.25	0.30	0.30	0.35	0.50	0.60	0.80
10	0.20	0.25	0.30	0.30	0.35	0.50	0.60	0.80
12	0.30	0.30	0.40	0.40	0.40	0.60	0.70	0.90
14	0.30	0.30	0.50	0.70	0.80	0.80	0.90	1.10
16	0.30	0.40	0.60	0.70	1.00	1.10	1.20	1.40
18	0.40	0.40	0.70	0.80	1.10	1.30	1.50	1.70
20	0.40	0.60	0.80	0.90	1.20	1.50	1.70	2.00
22	0.40	0.60	0.80	1.10	1.40	1.50	2.00	2.20

Manufacturing Profile

Nordfab Americas manufactures Quick-Fit Ducting in Thomasville NC, USA. Nordfab QF duct is a clamp-together design using a rolled edge design with a single lever clamp. The ducting and clamps are constructed from similar materials.

All clamps contain a standard gasket made of Nitrile which is suitable for most applications, including oil mist, as long as high temperatures are not an issue. Silicone and ePTFE gasket options are available for higher temperature applications. Nordfab Quick-Fit Ducting is available in 1" increments sized 3" to 24" diameter.

Engineering Specification

Ducting shall consist of the following:

- a. Galvanized: ASTM A653 with a G90 rating
 - i. Recommended max. service temperature is 390° F. At temperatures ranging between 390° F and 480° F, the zinc-iron alloy layers in galvanized steel will continue to provide a high level of protection from corrosion. However, there may be some peeling, changes in mechanical properties, and reduction in the corrosion protection.
- b. 304SS: Finish meets ASTM A240
 - i. Temp rating is 1100° F
- c. 316SS: Finish meets ASTM A240
 - i. Temp rating is 1100° F

Leakage Class Determined In Accordance With SMACNA Class 3

Ø in.	Avg. leakage per 100'	
	5" SP	10"SP
4 - 6	5 CFM	6 CFM
7 - 10	2.5 CFM	3.5 CFM
11 - 24	2 CFM	4 CFM

Ducting manufacturing techniques:

- a. Diameters 3" - 24" QF pipe, Quick-Fit Sleeves (adjustable nipples), and collars attached to other components will have one or both ends die formed-rolled to provide a uniform edge around the circumference of the rolled end. The pipe and sleeves shall have the longitudinal seam laser welded to allow for a tighter slip joint and reduce system pressure losses. All laser welded seams will undergo a light test to ensure there are no voids or imperfections in the system. Pipe lengths using laser welded seams will not exceed a nominal 60" length. The rolled end is used for clamping components together as well as offering reinforcement. Rolled edges provide structural support at 5' intervals or less and can be interpreted as a stiffener where SMACNA specifications are required.

A Quick-Fit Sleeve is used for adjustment during the install process. Pipe is cut to appropriate length and the Quick-Fit Sleeve secures the pipe for install.

- b. QF pipe and other QF components larger than 24" shall utilize either an angle flange or flat flange attached loosely and retained in place using a 3/8" vanstone lip. The flanged pipe shall have a solid welded seam and not exceed nominal 60" length. The angle or flat flanges provide structural support at 5' intervals or less and are considered as stiffeners where SMACNA specifications are required.
- c. Components which will be air direction sensitive will have an arrow label attached showing the proper flow direction.

Clamping rolled edged duct:

- a. Clamps shall be constructed with an over-center, spring-lever action for quick connecting of two pieces of ducting. A retaining pin shall be inserted in the handle and an eyelet on the clamp as a safety feature to ensure the handle does not prematurely come undone.
- b. When closing the clamp, the internal seal shall be compressed in such a manner as to cover both rolled beads for optimum sealing capacity in a full 360° pattern.

Standard Sealants	
Std	3M Scotch Seal Metal Sealant 2084
Optional	<ul style="list-style-type: none"> • Rock River Silicone Sealant • Red Devil HVAC/R High Temperature Silicone Sealant • Leak-free caulking: 3M™ Marine Adhesive/ Sealant Fast Cure 4000 UV

NOTE: Usage of non-standard sealant is noted on the product page.

Optional caulking and other materials governing system temperature ratings if applicable:

- a. Approved caulk is 3M Scotch Seal Metal Sealant 2084 or equivalent for system temperatures of 250°F or lower, AAMA Specification 801.1
- b. Optional approved caulk is 3M Polyurethane Adhesive Sealant 540 or equivalent for system temperatures of 250°F or lower
- c. Optional approved caulk is Rock River Silicone Sealant or equivalent for system temperatures of 400°F or lower; ASTM C920 Class 25, TT-S-00230C Class A and TT-S-001543A, FDA No 421 CFR 117.2600, conforms to FDA requirements
- d. Optional approved caulk is Red Devil HVAC/R High Temperature Silicone Sealant or equivalent for system temperatures of 500°F or lower, ASTM C920 Class 25, TT-S-

- 00230C Class A and TT-S-001543A, CEBTP 432.6 140-2, Mil Spec 46106A, CGSB 19C9-9B, DIN 18540 Part 2, OREX 150031-2
- e. Sealing o-rings
 - i. Buna-N, ASTM D2000 MBC610, 60 Durometer Hardness, with a temperature rating of 250°F maximum and is black in color, used with the Quick-Fit Sleeve.
 - ii. Silicone rubber, ASTM D2000 MGE705, 70 Durometer Hardness, and is red in color, used with the Quick-Fit Sleeve.
- f. Sealing gaskets
 - iii. Molded gaskets shall meet the material classification of ASTM D-2000 M2BG510 A24 B34 E014 E034 EF11 EF21 and used in systems where the temperature rating is 225°F or less and are black in color. This component shall be made using conductive materials for conductivity.
 - iv. Sponge o-ring shall meet the material classification of either ASTM D-1056-68 – SBE43 or ASTM D1056-85, 91, 98 – 2B3
- g. Clamp seals shall be made of one of the following:
 - 1. Nitrile to meet or exceed ASTM D1056 2B2 standards with a temperature rating not to exceed 158°F constant temperature (or intermittent temperature of 194°F).
 - 2. Silicone to meet or exceed ASTM D1056 2D2 standards with a temperature rating not to exceed 400°
 - 3. ePTFE not degraded by any common chemicals in the 0-14 PH range. Temperature rating shall not exceed 600°F.

Conductivity:

Metal-to-metal contact shall be obtained at all joint connections. Die-formed rolled edges are uniform in shape which provides the most consistent contact. The ears of the clamp contact with the rolled edges and provide maximum conductivity. Conductivity shall be adhered to per NFPA 77 paragraph 8.4.1.1; states all parts of the continuous metal piping system should have a resistance level that does not exceed 10 ohms. Testing is the responsibility of the owner.

Collapsibility Strength of QF Piping

Each size of duct piping has been third party tested for strength against collapsing. The piping was exposed to constant Positive pressure and constant vacuum. This testing was performed with sealed standard lengths of QF Pipe. Air was then slowly introduced as negative or positive pressure and the maximum value was held for 3 minutes. The table at left reflects the values held.

Pipe and fittings must be installed in accordance with Nordfab's standard specifications and standard accepted practices.

22ga / 20ga									
Duct Ø in.	Ga	Positive				Negative			
		PSI	in wg	Pascal	Bar	PSI	in wg	Pascal	Bar
3 - 12	22	80.60	2233.2326	555717.7	5.56	-2.6	-72.0398	-17926.4	-0.18
13 - 20	20	55.90	1548.8548	385417.1	3.85	-1.85	-51.2591	-12755.3	-0.13
21 - 24	20	40.95	1134.6262	282340.4	2.82	-1.63	-45.0249	-11204.0	-0.11
18ga									
Duct Ø in.	Ga	Positive				Negative			
		PSI	in wg	Pascal	Bar	PSI	in wg	Pascal	Bar
3 - 12	18	94.25	2611.4413	649831.13	6.50	-8.78	-243.134	-60501.5	-0.61
13 - 24	18	93.65	2594.8167	645694.27	6.46	-3.65	-101.133	-25165.9	-0.25
16ga									
Duct Ø in.	Ga	Positive				Negative			
		PSI	in wg	Pascal	Bar	PSI	in wg	Pascal	Bar
8- 16	16	94.25	2611.4413	649831.13	6.50	-8.91	-246.736	-17926.4	-0.61
17 - 24	16	66.95	1855.0238	461604.18	4.62	-6.18	-171.094	-11204.0	-0.43
14ga									
Duct Ø in.	Ga	Positive				Negative			
		PSI	in wg	Pascal	Bar	PSI	in wg	Pascal	Bar
8- 24	14	70.85	1963.0830	488493.7	4.88				

Quick Reference for Nordfab Ductwork in Various Operating Temperatures

Each component in a product must be evaluated to confirm temperature vulnerabilities.

Operating Temperature of Ductwork Components																
° F	Pipe, Elbows, Branches & Other Metal Components				Caulks				Seals in QF Clamp			O-Rings for Quick-Fit Sleeves (adjustable nipples)		Flange Gasket		
2600°																
1100°																
600°																
500°																
450°																
400°																
390°																
250°																
190°																
158°	Galvanized Steel	304SS	Black Metal	Black Metal Painted	3M™ Scotch Seal Metal Sealant 2084	Rock River Silicone Sealant	Red Devil HVAC/R High Temp Silicone Sealant	Leak-free caulking: 3M Marine Adhesive/ Sealant Fast Cure 4000 UV	3M Polyurethane Adhesive Sealant 560	Nitrile	Silicone (intermittent to 500° F, max. one hour)	ePTFE	Black O-Ring	Red Silicone O-Ring	Nitrile	Silicone
-20°																
-40°																
-60°																
-65°																
-75°																
-82°																

This information is intended as a general recommendation. Each component in a ductwork system should be analyzed for temperature vulnerabilities (example: Rubber seals in blast gates have a lower temperature rating than the metal housing.) See individual product pages for notes regarding components with additional temperature limitations.

Quick-Fit® Clamp with Pin

Ordering Information

- Galvanized and Stainless Steel QF Clamps are standard from factory with Nitrile seal and bridge pin.
- Silicone or ePTFE seals are optional - specify when ordering. Clamps also may be ordered optionally without seals.
- Galvanized clamp supplied with galvanized bridge pin. SS clamp supplied with SS bridge pin.
- 3" to 6" QF Clamps: Small bridge pin with 3/8" wide seal from factory.
- 7" to 11" QF Clamps: Large bridge pin with 1/2" wide seal from factory.
- 12" to 24" QF Clamps: Large bridge pin with 5/8" wide seal from factory.
- Replacement seals: Nitrile and Silicone seals stocked in rolls of 50'. ePTFE seals stocked in rolls of 100'.



Ø in.	Weight Lbs
3	0.26
4	0.28
5	0.31
6	0.33
7	0.54
8	0.59
9	0.63
10	0.68
11	0.70
12	1.32
13	1.38
14	1.48
15	1.53
16	1.60
17	1.67
18	1.77
19	1.85
20	1.92
21	1.98
22	2.04
23	2.10
24	2.20

Material Options

	QF Clamps Galv or SS with Nitrile Seals		QF Clamps Galv or SS with Silicone Seals		QF Clamps Galv or SS with ePTFE Seals			
	Size (in)		Size (in)		Size (in)			
	Min. Ø	Max. Ø	Min. Ø	Max. Ø	Min. Ø	Max. Ø		
Standard	3	24	Optional	3	24	Optional	3	24

What is the best seal for my application?

Nitrile seals are inserted into QF Clamps as standard. Rated for max. intermittent service temperatures of 194° and continuous 158° F. There is no additional charge for nitrile so it is the most economical choice.

Silicone seals are an economically priced option for operating temperatures above 158° F. Rated for max. service temperature of 400° F, silicone has an extremely broad temperature range capability as it is also very good in low temperatures, remaining flexible at -60° F. Additionally, silicone offers superb resistance to weather aging and ozone.

ePTFE seals are not degraded by any common chemicals (0 - 14 pH range) FOR INDUSTRIAL USE ONLY. Not for use in food, drug, cosmetic or medical device manufacturing, processing, or packaging operations. Max. temperature rating of 600° F.

Quick Tick Online™
 Nordfab's dealer tool for quick quoting & ordering — the correct quantity of clamps automatically will be added to your order

Pipe

Ordering Information

- When ordering, specify material, gauge (if non-standard), dimension and end types.
- QF clamp-together Pipe is quick and easy to install, saving time and money on installation.
- Solid welded seams prevent leakage.
- Length is nominal 5'.
- Pipe larger than 24" diameter is flanged and constructed of highly durable 16 gauge material. Flanges are industry standard angle rings.



QF Pipe



Flanged Pipe

Ø in.	Length in.	QF Std Pipe Weight Lbs	AFL Std Pipe Weight Lbs	QF 14ga Pipe Weight Lbs
3	59.25	4.00	5.40	
4	59.25	5.35	7.05	
5	59.25	6.65	9.05	
6	59.25	7.93	10.73	
7	59.06	11.70	15.70	
8	59.06	13.25	17.75	36
9	59.06	14.92	19.92	40
10	58.75	16.60	23.10	44
11	58.75	18.10	25.10	49
12	58.75	19.75	27.75	53
13	58.75	21.40	29.90	57
14	58.75	27.30	36.80	61
15	58.75	29.25	44.25	66
16	58.75	31.15	47.15	70
17	58.75	33.09	49.59	74
18	58.75	34.00	51.00	79
19	58.75	36.00	55.00	83
20	58.75	38.00	57.00	87
21	58.75	40.00	59.5	92
22	58.75	42.00	63.50	96
23	58.75	44.00	65.5	100
24	58.75	45.82	68.82	104
26	59.00		98.56	
28	59.00		118.00	
30	59.00		137.05	
32	59.00		145.94	
34	59.00		154.83	
36	59.00		162.76	
38	59.00		173.47	
40	59.00		182.81	

QF Material Options

Galv				SS		
Gauges	Size (inches)		Gauges	Size (inches)		
	Min. Ø	Max. Ø		Min. Ø	Max. Ø	
Standard	22	3	12	22	3	12
	20	13	24	20	13	24
Optional	18	4	24	18	8	24
	16	8	24	16	8	24
	14	8	24			

Flanged Material Options

Galv (Std)				SS		
Gauges	Size (inches)		Gauges	Size (inches)		
	Min. Ø	Max. Ø		Min. Ø	Max. Ø	
Standard	22	3	12	22	3	12
	20	13	24	20	13	24
	16	26	40	16	26	40
	14	42	50	20	4	12
	12	52	72	18	8	24
Optional	20	4	12	16	8	24
	18	4	24			
	16	8	24			
	14	8	50			
	12	10	72			
	10	12	72			

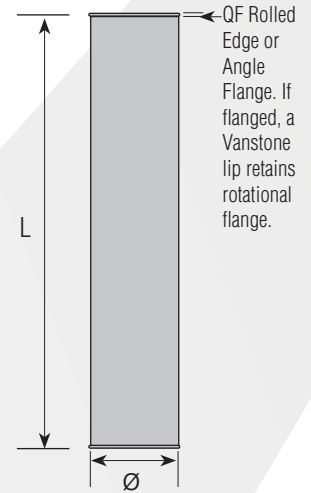

Construction

Seam: Longitudinal seam is laser or plasma welded (laser weld sizes 3" to 24" diameter, plasma weld on larger diameters).

Optional End Types

Standard QF end can be changed to Raw ID (RI), Raw OD (RO), No Fitting (NF), Hose Adapter (RF), Flat Flange (FLL), Angle Flange (AFL), or Van Stone (VS).

All pipe larger than 24" is flanged, rotational Angle Flange is standard. Welded flanges optional.

Did you know that Nordfab is the only manufacturer of **14 gauge** clamp-together duct?

Quick-Fit® Sleeve with O-Ring

Ordering Information

- Used to provide variable length adjustment of QF System. Each QF pipe section is 5 ft. in length. To accommodate an existing span of less than 5', a sleeve is used to shorten. Formerly known as Adjustable Nipple.
- Solid welded seams prevent leakage.
- Nitrile (black) O-ring included standard.
- Specify Silicone (red) O-ring (high temp rating) if needed (additional cost). Replace on-site.

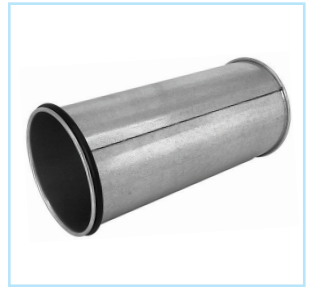

Construction

Longitudinal seam is laser welded.

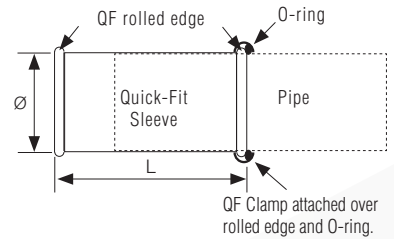

Ø in.	ID in.	OD in.	Rolled Edge (nom in.)	L in.	Weight Lbs
3	3.12	3.19	0.2	11.250	0.80
4	3.96	4.03	0.2	11.375	1.05
5	4.96	5.03	0.2	11.375	1.30
6	5.99	6.06	0.2	11.375	1.60
7	7.01	7.07	0.3	11.125	2.40
8	8.00	8.06	0.3	11.125	2.70
9	9.00	9.07	0.3	11.125	3.05
10	10.00	10.07	0.3	11.125	3.40
11	11.00	11.07	0.3	11.125	3.80
12	12.11	12.17	0.4	10.875	4.20
13	13.11	13.19	0.4	10.875	4.70
14	14.10	14.18	0.4	10.875	5.85
15	15.10	15.18	0.4	10.875	6.25
16	16.10	16.18	0.4	10.875	6.65
17	17.11	17.19	0.4	10.875	7.45
18	18.10	18.18	0.4	10.875	7.45
19	19.10	19.18	0.4	10.875	8.10
20	20.10	20.18	0.4	10.875	8.80
21	21.10	21.18	0.4	10.875	9.70
22	22.11	22.19	0.4	10.875	8.10
23	23.11	23.19	0.4	10.875	8.80
24	24.06	24.14	0.4	10.875	9.70

QF Material Options

Galv			SS		
Gauges	Size (inches)		Gauges	Size (inches)	
	Min. Ø	Max. Ø		Min. Ø	Max. Ø
Standard	22	3	12	22	3
	20	13	24	20	13
Optional	18	4	24		

The Quick-Fit Sleeve provides an easy way to adjust in areas where you need straight duct sections shorter than 5'

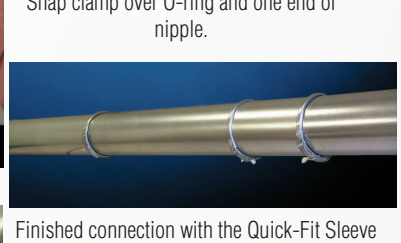
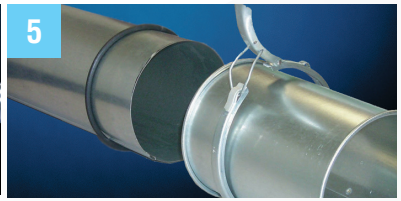
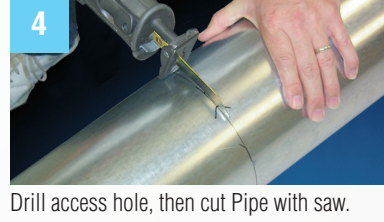
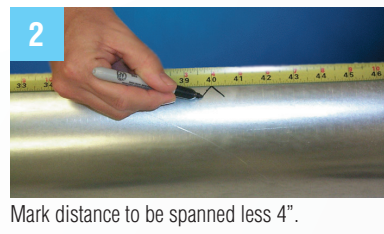

NOTE: POSITION CUT PIPE IN THE SAME DIRECTION AS THE AIRFLOW.

O-Ring for Quick-Fit Sleeve

Ordering Information

- Replacement O-ring for use with Quick-Fit Sleeve.
- Specify Black for standard applications.
- Specify Red for high temp material. Higher quantities may require 7 - 10 working days lead time.

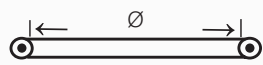
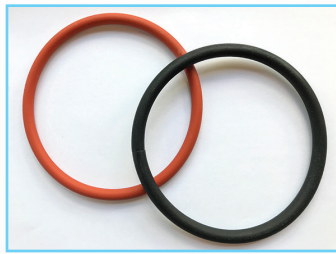

Ø ID in.	Cord Ø mm	Weight Lbs
3	7	0.01
4	7	0.02
5	7	0.03
6	7	0.04
7	9	0.08
8	9	0.09
9	9	0.10
10	9	0.11
11	9	0.17
12	11	0.22
13	11	0.23
14	11	0.25
15	11	0.26
16	11	0.27
17	11	0.28
18	11	0.29
20	11	0.30
22	11	0.31
24	11	0.33

Quick-Fit® Sleeve Assembly

Ordering Information

- The 16ga Quick-Fit Sleeve Assembly includes 16 gauge cut pipe, QF Clamp, and standard gauge Quick-Fit Sleeve with black O-ring.
- The 14 gauge Quick-Fit Sleeve Assembly is used to provide variable length adjustment of 14 gauge pipe with QF ends. The assembly includes one 8.5" long, standard gauge, Quick-Fit Sleeve with O-ring, one nominally 59" long 14ga Duct Pipe, and one QF Clamp. The Pipe has a QF rolled edge on one end, for connection to other QF end ductwork, and is raw on the other end. The raw end can be trimmed during installation to complete duct spans less than 5 feet in length.
- Quick-Fit Sleeve Assemblies can not be ordered in custom lengths.
- For vertical or horizontal installation.
- In all applications, duct must be supported in compliance with local regulations.
- For high temperature applications, red O-ring* and QF Clamp with Silicone Seal or QF Clamp with ePTFE Seal may be needed (additional cost). Specify O-ring and Clamp Seal type.

Please note that Nordfab's standard Quick-Fit Sleeve is not interchangeable with pipe included as part of the Quick-Fit Sleeve Assembly as the ID of the Sleeves is different.



Construction
Seam: Longitudinal seam on Quick-Fit Sleeve is laser welded. Pipe seam is plasma welded.

Optional End Types
 QF only.

Ø in.	Weight Lbs
8	39
9	43
10	47
11	53
12	57
13	62
14	67
15	72
16	77
17	81
18	86
20	95
22	105
24	114

Galv				SS			
		Size (inches)				Size (inches)	
Gauges		Min. Ø	Max. Ø	Gauges		Min. Ø	Max. Ø
Standard	16 (pipe) 22 (sleeve)	8	12	Standard	18ga or 16ga pipe will incl. 22ga sleeve	8	12
	16 (pipe) 20 (sleeve)	13	24		18ga or 16ga pipe will incl. 20ga sleeve	13	24
Optional	14 (pipe) 22 (sleeve)	8	12				
	14 (pipe) 20 (sleeve)	13	24				



Measure distance to be spanned.

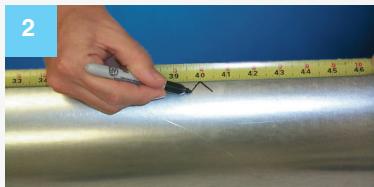

On raw end of provided Pipe, mark the distance to be spanned **less 1"**.

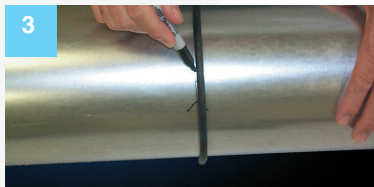

Use provided O-ring to mark for cut.



Drill access hole, then cut Pipe with saw.

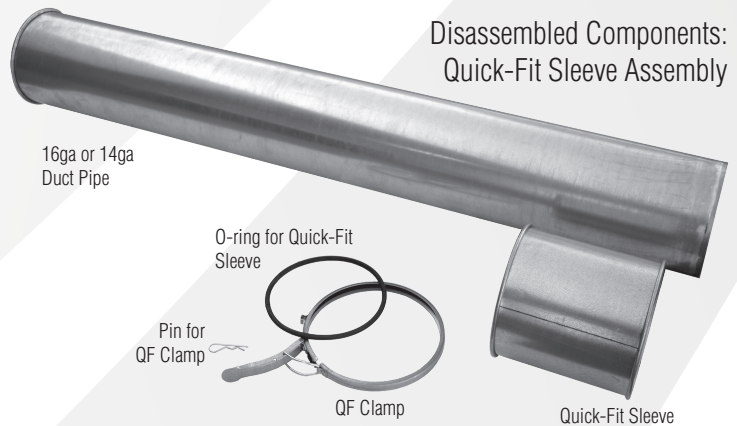

Disassembled Components: Quick-Fit Sleeve Assembly

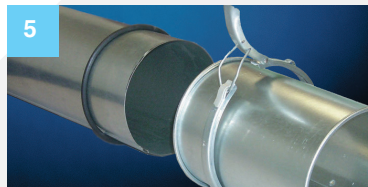

Put O-ring on the cut piece of Pipe and slide the provided Quick-Fit Sleeve over the Pipe.



Place QF Clamp over the O-ring and end of Quick-Fit Sleeve.

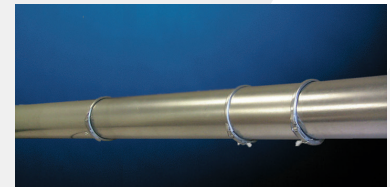

Finished connection

Adhere to our instructions.

- For vertical or horizontal installation. Keep cut end of Pipe in the same direction as the air flow.
- In all applications duct must be supported in compliance with local regulations.

Angle Flange

Ordering Information

- When ordering, specify material and dimension.

- Flat Flanges also available with custom drill patterns. ANSI Flange patterns are charged double the standard. Call for pricing on other options.

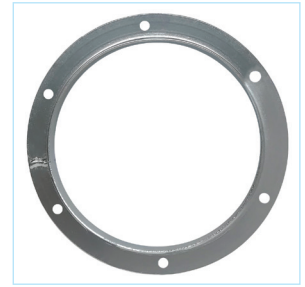

Ø in.	ID in.	OD in.	H in.	T in.	Qty holes	Hole Ø in.	Bolt Circle in.	Weight Lbs
3	3.06	5.06	1	.125	6	9/32	4.31	.70
4	4.06	6.06	1	.125	6	9/32	5.31	.85
5	5.06	7.06	1	.125	6	9/32	6.31	1.18
6	6.09	8.59	1.25	.125	6	9/32	7.31	1.38
7	7.13	9.63	1.25	.125	6	3/8	8.50	1.73
8	8.13	10.63	1.25	.125	6	3/8	9.56	1.90
9	9.13	11.63	1.25	.125	6	7/16	10.63	2.55
10	10.13	12.63	1.25	.125	6	7/16	11.81	3.05
11	11.13	13.63	1.25	.125	6	7/16	12.75	3.25
12	12.13	15.13	1.5	.125	8	7/16	14.00	3.88
13	13.13	16.13	1.5	.125	8	7/16	15.00	4.25
14	14.13	17.13	1.5	.125	8	7/16	16.00	4.75
15	15.13	18.13	1.5	.125	8	7/16	17.00	7.25
16	16.13	19.13	1.5	.1875	8	7/16	18.00	8.00
17	17.13	20.13	1.5	.1875	8	7/16	19.00	8.25
18	18.13	21.13	1.5	.1875	8	7/16	20.00	8.50
19	19.13	22.13	1.5	.1875	12	7/16	20.75	8.75
20	20.13	23.13	1.5	.1875	12	7/16	21.75	9.50
21	21.13	24.13	1.5	.1875	12	7/16	22.75	10.25
22	22.13	25.13	1.5	.1875	12	7/16	23.75	10.75
23	23.13	26.13	1.5	.1875	12	7/16	24.88	11.25
24	24.13	27.13	1.5	.1875	12	7/16	25.88	11.50
25	25.13	28.13	1.5	.1875	16	7/16	26.88	12.00
26	26.13	30.13	2	.1875	16	7/16	28.38	16.75
27	27.13	31.13	2	.1875	16	7/16	29.38	17.38
28	28.13	32.13	2	.1875	16	7/16	30.38	18.00
29	29.13	33.13	2	.1875	16	7/16	31.38	18.75
30	30.13	34.13	2	.1875	16	7/16	32.38	19.50
31	31.13	35.13	2	.1875	16	7/16	33.38	20.38
32	32.13	36.13	2	.1875	16	7/16	34.38	20.75
33	33.13	37.13	2	.1875	16	7/16	35.38	21.25
34	34.13	38.13	2	.1875	16	7/16	36.38	22.00
35	35.13	39.13	2	.1875	16	7/16	37.38	22.50
36	36.13	40.13	2	.1875	16	7/16	38.38	23.00
37	37.13	41.13	2	.1875	24	7/16	39.38	23.75
38	38.13	42.13	2	.1875	24	7/16	40.38	24.50
39	39.13	43.13	2	.1875	24	7/16	41.38	25.00
40	40.13	44.13	2	.1875	24	7/16	42.38	25.75
42	42.13	46.13	2	.1875	24	7/16	44.38	26.50
44	44.13	48.13	2	.1875	24	7/16	46.38	28.00
46	46.13	50.13	2	.1875	24	7/16	48.38	29.00
48	48.13	52.13	2	.1875	24	7/16	50.38	30.75
50	50.13	54.13	2	.1875	24	7/16	52.38	32.00
52	52.13	56.13	2	.1875	24	7/16	54.38	33.40
54	54.13	58.13	2	.1875	24	7/16	56.38	34.80
56	56.13	60.13	2	.1875	24	7/16	58.38	36.00
58	58.14	62.14	2	.1875	32	7/16	60.38	37.00
60	60.13	64.13	2	.1875	32	7/16	62.38	38.50
62	62.13	66.13	2	.1875	32	7/16	64.38	39.80
64	64.13	68.13	2	.1875	32	7/16	66.38	41.00
66	66.13	70.13	2	.1875	36	7/16	68.38	42.40
68	68.13	72.13	2	.1875	36	7/16	70.38	43.50
70	70.13	74.13	2	.1875	36	7/16	72.38	44.90
72	72.13	76.13	2	.1875	36	7/16	74.38	46.30

Material Options

Galv		SS	
Size (in)		Size (in)	
Min. Ø	Max. Ø	Min. Ø	Max. Ø
3	72	3	40

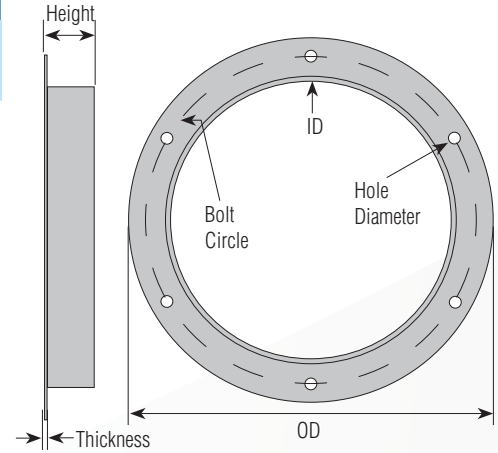

Notes:

- Angle flanges are only available with the shown hole patterns.
- For different hole patterns or no holes, Nordfab can use laser technology to burn flat flanges to match your needs.

Hardware:

Hardware is not supplied with flanges and must be supplied by customer:

- 7/16" holes – use 3/8-16 x 1-1/2" lockwasher, and hex nut - Grade 5 or better
- 3/8" holes – use 5/16-18 x 1-1/2" lockwasher, and hex nut - Grade 5 or better
- 9/32" holes – use 1/4-20 x 1-1/2" lockwasher, and hex nut - Grade 5 or better

Angle Flange Gasket

Ordering Information

- When ordering, specify material, dimension.
- Black nitrile standard. 50 durometer. Temp range -65°F to 450°F.
- Nitrite material is conductive. 60 durometer. Temp range -20°F to 170°F.
- Red silicone optional. 50 durometer. Temp range -65°F to 450°F.
- One gasket needed per joint.

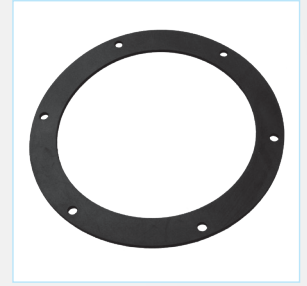

ø in.	ID in.	OD in.	Width in.	Thickness in.		Number of holes	Hole ø in.	Bolt Circle in.
				Nitrile	Silicone			
3 *	3.06	5.06	1			6	9/32	4.31
4	4.06	6.06	1			6	9/32	5.31
5 *	5.06	7.06	1			6	9/32	6.31
6	6.09	8.59	1.25			6	9/32	7.31
7 *	7.13	9.63	1.25			6	3/8	8.50
8	8.13	10.63	1.25			6	3/8	9.56
9 *	9.13	11.63	1.25			6	7/16	10.63
10	10.13	12.63	1.25			6	7/16	11.81
11 *	11.13	13.63	1.25			6	7/16	12.75
12	12.13	15.13	1.5			8	7/16	14.00
13 *	13.13	16.13	1.5			8	7/16	15.00
14 *	14.13	17.13	1.5			8	7/16	16.00
15 *	15.13	18.13	1.5			8	7/16	17.00
16 *	16.13	19.13	1.5			8	7/16	18.00
17 *	17.13	20.13	1.5			8	7/16	19.00
18 *	18.13	21.13	1.5			8	7/16	20.00
19 *	19.13	22.13	1.5			12	7/16	20.75
20 *	20.13	23.13	1.5			12	7/16	21.75
21 **	21.13	24.13	1.5			12	7/16	22.75
22 *	22.13	25.13	1.5			12	7/16	23.75
23 **	23.13	26.13	1.5			12	7/16	24.88
24 *	24.13	27.13	1.5			12	7/16	25.88
25 **	25.13	28.13	1.5			16	7/16	26.88
26 **	26.13	30.13	2			16	7/16	28.38
27 **	27.13	31.13	2			16	7/16	29.38
28 **	28.13	32.13	2			16	7/16	30.38
29 **	29.13	33.13	2			16	7/16	31.38
30 **	30.13	34.13	2	.1875	.125	16	7/16	32.38
31 **	31.13	35.13	2			16	7/16	33.38
32 **	32.13	36.13	2			16	7/16	34.38
33 **	33.13	37.13	2			16	7/16	35.38
34 **	34.13	38.13	2			16	7/16	36.38
35 **	35.13	39.13	2			16	7/16	37.38
36 **	36.13	40.13	2			16	7/16	38.38
37 **	37.13	41.13	2			24	7/16	39.38
38 **	38.13	42.13	2			24	7/16	40.38
39 **	39.13	43.13	2			24	7/16	41.38
40 **	40.13	44.13	2			24	7/16	42.38
42 **	42.13	46.13	2			24	7/16	44.38
44 **	44.13	48.13	2			24	7/16	46.38
• 46 **	46.13	50.13	2			24	7/16	48.38
• 48 **	48.13	52.13	2			24	7/16	50.38
• 50 **	50.13	54.13	2			24	7/16	52.38
• 52 **	52.13	56.13	2			24	7/16	54.38
• 54 **	54.13	58.13	2			24	7/16	56.38
• 56 **	56.13	60.13	2			24	7/16	58.38
• 58 **	58.14	62.14	2			32	7/16	60.38
• 60 **	60.13	64.13	2			32	7/16	62.38
• 62 **	62.13	66.13	2			32	7/16	64.38
• 64 **	64.13	68.13	2			32	7/16	66.38
• 66 **	66.13	70.13	2			36	7/16	68.38
• 68 **	68.13	72.13	2			36	7/16	70.38
• 70 **	70.13	74.13	2			36	7/16	72.38
• 72 **	72.13	76.13	2			36	7/16	74.38

Material Options

Standard	Nitrile	
	Size (in)	Max. ø
	Min. ø	ø
	3	72
Optional	Silicone	
	Size (in)	Max. ø
	Min. ø	ø
	3	72

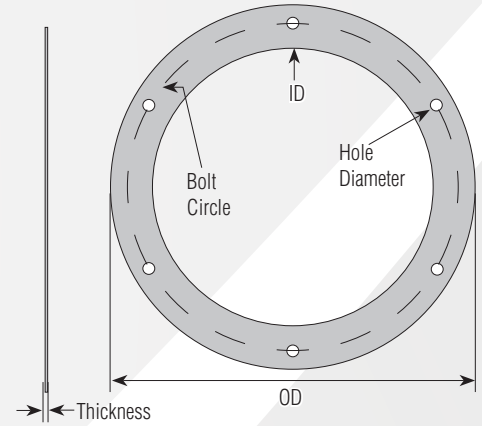

Note:

Angle flange gaskets are available only with the shown hole patterns.

Nitrile

- Tensile PSI: 900
- Elongation, %: 200

Silicone

- Tensile PSI: 725
- Elongation, %: 250

* Silicone Flange 10 days lead time
 ** Both Nitrile and Silicone are 10 days lead time
 • Sizes 46" and above are pieced gaskets

Elbow

Ordering Information

- When ordering, specify material, gauge (if non-standard), dimension and end types, degree (30°, 45°, 60°, or 90°).
- Elbows in heavier gauges can be supplied in solid welded construction at an additional cost.
- Other CLR's available upon request.

16 Gauge Elbows:

- 16ga Elbows are constructed of gores lapped over one another and spot welded.
- This is a directional elbow supplied with an arrow to indicate the direction of flow. Please specify direction if ordering ends other than QF.
- Interior buffing available with upcharge.
- Galvanized is 16 gauge with 16 gauge collars. SS is 16ga with 20ga collars.

14 Gauge Galvanized Elbows:

- Constructed of butt-welded gores.
- Interior buffing available with upcharge.
- If flanged, vanstone ends with rotational Angle Flanges standard. Welded flanges will be clocked at the centerline as standard.

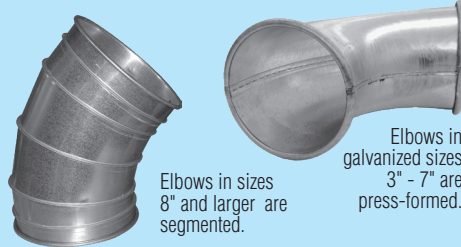

Degrees	30°	45°	60°	90°
Diameters CLR's	3" - 7"	1.0**	8" and larger	1.5

Notes: * 1.0 Galv and 1.5 SS

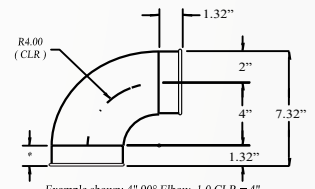

Note: Overall height calculation only works with 90° elbows.

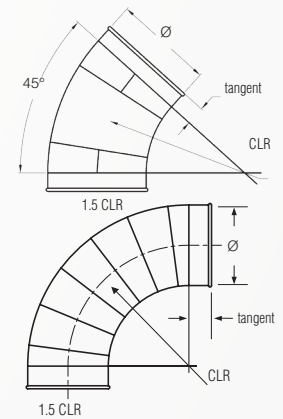

Notes: CLR= Center Line radius

Ø in.	QF Std Weight Lbs	QF 16ga Weight Lbs	QF 14ga Weight Lbs	AFL Std Weight Lbs	AFL 14ga Weight Lbs
3	0.90			1.75	
4	1.00			2.25	
5	1.20			2.80	
6	1.50			3.85	
7	2.20	9.42		4.90	
8	6.10	13.64	19	7.66	23
9	7.60	16.64	24	8.45	29
10	9.00	21.54	29	15.47	35
11	10.50	27.65	35	17.60	41
12	12.40	33.76	42	19.33	49
13	14.26	40.07	46	22.40	54
14	19.00	46.38	50	25.39	59
15	21.25	52.61	54	27.90	69
16	24.00	58.83	59	30.51	75
17	27.50	66.14	63	32.30	80
18	30.90	73.44	68	34.67	85
20	35.97	85.40	97	41.99	110
22	43.06	107.98	103	46.90	124
24	55.50	132.63	131	70.96	154
26				89.12	178
28				99.19	214
30				110.26	233
32				121.38	274
34				133.52	295
36				149.04	340
38				162.31	363
40				176.20	414

QF Material Options

	Galv			SS			
	Gauges	Size (inches)		Gauges	Size (inches)		
		Min. Ø	Max. Ø		Min. Ø	Max. Ø	
Standard	24	3	7	Standard	3" - 6" See tubed elbows on pg. 16		
	22	8	12		22	7	12
	20	13	24		20	13	24
Optional	16	7	24	Optional	18	8	24
	14	8	24		16	8	24

Flanged Material Options

	Galv			SS			
	Gauges	Size (inches)		Gauges	Size (inches)		
		Min. Ø	Max. Ø		Min. Ø	Max. Ø	
Standard	24	3	7	Standard	3" - 6" See tubed elbows on pg. 16		
	22	8	12		22	7	12
	20	13	24		20	13	24
	18	26	30		18	26	30
	16	32	40		16	32	40
	14	42	50		14	42	50
Optional	12	52	72	Optional	20	8	12
	20	8	12		18	8	24
	18	8	24		16	8	30
	16	8	30		14	8	50
	12	10	72		10	12	72

Ø in.	Tangents QF		Tangents AFL	
	Galv	SS	Galv	SS
3	2.00	2.00		
4	1.32	2.00		
5	1.32	2.00	2.00	2.00
6	1.32	2.00		
7	1.32	2.25		
8 to 15	2.00	2.00		
16 to 24	2.00	2.00	4.00	4.00
26 to 40				

Elbow

Construction

3"-7":

Standard galvanized steel 3" to 7" elbows are press formed. Press formed halves are stitch welded together with rolled ends. Stainless steel 3" to 6" elbows are tubed. Press formed halves are stitch welded together with rolled ends.

8" to 24":

8" and larger elbows shown here are gored (segmented) construction with a lock form standing seam every 15°. Gores are spot welded and caulked.

These elbows are produced as follows:

Degree of angle	Number of gores
30°	(1) 15° + (2) 7.5° + (2) tangents
45°	(2) 15° + (2) 7.5° + (2) tangents
60°	(3) 15° + (2) 7.5° + (2) tangents
90°	(5) 15° + (2) 7.5° + (2) tangents

Optional End Types

Standard QF end can be changed to Raw ID (RI), Raw OD (RO), No Fitting (NF), Hose Adapter (RF), Flat Flange (FFL), Angle Flange (AFL), or Van Stone (VS). Angle Flange (AFL) - Nordfab Angle Flange is industry standard angle flange with pre-drilled holes.

Collars: Collar is located on the exterior side of each port and considered as airflow non-directional. Collars have a laser welded longitudinal seam. If air flow directional product is required, it must be stated on the PO and additional cost may be incurred. A raised lap seam and spot weld are used for attaching the collar to the body and no caulking is used. If caulking is required, additional cost is incurred.

Elbow Long Radius

Ordering Information

- When ordering, specify material, gauge (if non-standard), dimension, end types, degree (30°, 45°, 60°, or 90°) and note LR (Long Radius).
- Elbows in heavier gauges can be supplied in solid welded construction at an additional cost.
- Other CLR's available upon request.

16 Gauge Elbows:

- 16ga Elbows are constructed of gores lapped over one another and spot welded.
- This is a directional elbow supplied with an arrow to indicate the direction of flow. Please specify direction if ordering ends other than QF.
- Interior buffing available with upcharge.
- Galvanized is 16 gauge with 16 gauge collars. SS is 16ga with 20ga collars.

14 Gauge Galvanized Elbows:

- Constructed of butt-welded gores.
- Interior buffing available with upcharge.
- If flanged, vanstone ends with rotational Angle Flanges standard. Welded flanges will be clocked at the centerline as standard.
- One additional gore is included on each degree style.



Elbows in SS sizes 3" - 6" are Tubed.



Degrees	30°	
	45°	
	60°	
	90°	
Diameters CLR's	3" - 7"	1.5**
	8 - 24"	2.5

Notes: * 1.5 Galv and 2.5 SS

Construction

3"-7":

Standard galvanized steel 3" to 7" elbows are press formed. Press formed halves are stitch welded together with rolled ends. Stainless steel 3" to 6" elbows are tubed. Press formed halves are stitch welded together with rolled ends.

8" to 24":

8" and larger elbows shown here are gored (segmented) construction with a lock form standing seam every 15°. Gores are spot welded and caulked. See standard radius Elbow above for number of gores.

QF Material Options

		Galv			SS		
		Size (inches)			Size (inches)		
		Min.	Max.		Min.	Max.	
Gauges		Ø	Ø	Gauges	Ø	Ø	
Standard	24	3	7	Standard	3" - 6" See tubed elbows on pg. 16		
	22	8	12		22	7	12
	20	13	24		20	13	24
Optional	16	7	24	Optional	18	8	24
	14	8	24		16	8	24

Flanged Material Options

		Galv			SS		
		Size (inches)			Size (inches)		
		Min.	Max.		Min.	Max.	
Gauges		Ø	Ø	Gauges	Ø	Ø	
Standard	24	3	7	Standard	3" - 6" See tubed elbows on pg. 16		
	22	8	12		22	7	12
	20	13	24		20	13	24
	18	26	30		18	26	32
	16	32	40		16	32	40
	14	42	50		14	42	50
Optional	12	52	72	Optional	20	8	12
	20	8	12		18	8	24
	18	8	24		16	8	30
	16	8	30		14	8	50
	12	10	72		12	10	72
10	12	72	10	12	72		

End Types

Standard QF end can be changed to Raw ID (RI), Raw OD (RO), No Fitting (NF), Hose Adapter (RF), Flat Flange (FFL), Angle Flange (AFL), or Van Stone (VS). Angle Flange (AFL) - Nordfab Angle Flange is industry standard angle flange with pre-drilled holes.

Collars: Collar is located on the exterior side of each port and considered as airflow non-directional. Collars have a laser welded longitudinal seam. If air flow directional product is required, it must be stated on the PO and additional cost may be incurred. A raised lap seam and spot weld are used for attaching the collar to the body and no caulking is used. If caulking is required, additional cost is incurred.

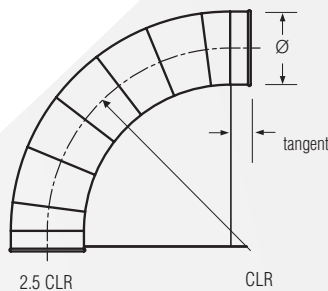

Notes: CLR= Center Line radius
** 7" Ø 16Ga elbow has a 2.5CLR

Elbow Tubed

Ordering Information

- When ordering, specify material, gauge (if non-standard), dimension and degree (30°, 45°, 60°, or 90°).
- Tubed elbows are airflow directional (collar on outside of tube for outlet and collar on inside of tube for inlet).
- Please specify direction if ordering end types other than QF.



Ø in.	Weight Lbs
3	3.50
4	5.00
5	7.40
6	10.25
8	15.00

QF Material Options

Galv				SS			
Gauges	Size (inches)		Gauges	Size (inches)			
	Min. Ø	Max. Ø		Min. Ø	Max. Ø		
Std	16	3	Std	14	3	8	
	14	5		8			

Degrees	30° 45° 60° 90°
Diameters CLR's	3" - 8" 1.5

Flanged Material Options

Galv				SS			
Gauges	Size (inches)		Gauges	Size (inches)			
	Min. Ø	Max. Ø		Min. Ø	Max. Ø		
Std	16	3	Std	14	3	8	
	14	5		8			

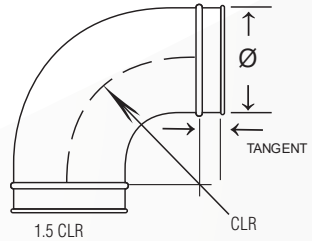

Construction

Standard galvanized steel tube.

Optional End Types

Standard QF end can be changed to Raw ID (RI), Raw OD (RO), No Fitting (NF), Hose Adapter (RF), Flat Flange (FLL), Angle Flange (AFL), or Van Stone (VS). Nordfab Angle Flange is industry standard angle flange with pre-drilled holes.

Collars:

Each end has 2" long collars with one collar on the outside of the tube and another on the inside to make the elbow airflow directional. Please specify direction if ordering varying ends. Collars have a laser welded longitudinal seam. A raised lap seam and spot weld are used for attaching the collar to the body and no caulking is used. If caulking is required, additional cost is incurred.

Elbow Tubed Long Radius

Ordering Information

- When ordering, specify material, gauge (if non-standard), dimension and degree (30°, 45°, 60°, or 90°).
- Tubed elbows are airflow directional (collar on outside of tube for outlet and collar on inside of tube for inlet).
- Please specify direction if ordering end types other than QF.



Ø in.	Weight Lbs
3	5.00
4	7.00
5	11.25
6	14.75
8	25.00

QF Material Options

Galv				SS			
Gauges	Size (inches)		Gauges	Size (inches)			
	Min. Ø	Max. Ø		Min. Ø	Max. Ø		
Std	16	3	Std	14	3	8	
	14	5		8			

See Elbow Tubed for Construction, End Types, and Collars information.

Degrees	30° 45° 60° 90°
Diameters CLR's	3" - 8" 2.5

Flanged Material Options

Galv				SS			
Gauges	Size (inches)		Gauges	Size (inches)			
	Min. Ø	Max. Ø		Min. Ø	Max. Ø		
Std	16	3	Std	14	3	8	
	14	5		8			

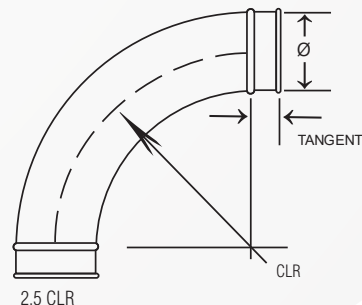

Branch

Ordering Information

- When ordering, specify material, gauge (if non-standard), dimensions A, B, C, end types, and angle (standard 30°, optional 45°).
- A - C ≥ C-B
- Use formula above to determine if a reducer is needed at C.

14 Gauge Branches:

- Any Branch with B, or C end smaller than 8" will be hybrid. (Smaller section will be a lighter gauge.)

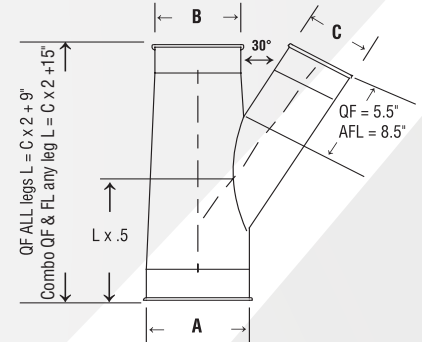

A Ø in.	Length in.	Weight Lbs
3		2.32
4		3.00
5		3.75
6		4.25
7		5.00
8		6.00
9		7.25
10		8.50
11	QF or Raw ends: Length = C X 2 + 9"	9.25
12		10.75
13		11.40
14	To manufacture, A - C must be greater to or equal to C - B	13.50
15		15.60
16		17.56
17		19.00
18		21.00
19		25.00
20		30.00
21		35.00
22		39.50
23		47.00
24	53.50	
25	Angle Flange or Flat Flange ends: Length = C X 2 + 15"	63.00
26		74.00
27		81.00
28		98.00
29		107.00
30		117.05
31		121.00
32		125.94
33		130.00
34		To manufacture, A - C must be greater to or equal to C - B
35	138.00	
36	142.78	
37	148.00	
38	153.47	
39	158.00	
40	162.81	

QF Material Options

Galv				SS			
Gauges	Size (inches)		Gauges	Size (inches)			
	Min. Ø	Max. Ø		Min. Ø	Max. Ø		
Standard	22	3	12	22	3	12	
	20	13	24	20	13	24	
Optional	18	4	24	18	8	24	
	16	8	24	16	8	24	

Flanged Material Options

Galv				SS			
Gauges	Size (inches)		Gauges	Size (inches)			
	Min. Ø	Max. Ø		Min. Ø	Max. Ø		
Standard	22	3	12	22	3	12	
	20	13	24	20	13	24	
	18	26	30	18	26	30	
	16	32	40	16	32	40	
	14	42	50	20	4	12	
Optional	12	52	72	18	8	24	
	20	4	12	16	8	30	
	18	4	24				
	16	8	30				
	14	8	50				
	12	10	72				
	10	12	72				

Please carefully note Nordfab Branch End Label designations (ABC)

Construction

Seam: Longitudinal seam is lapped, spot welded, and caulked on standard gauges. 14ga and 12ga - Solid butt welds.

Collars: Located on the exterior side of each port and considered as air flow non-directional. Collars have a laser welded longitudinal seam. If air flow directional product is required, it must be stated on the PO and additional cost may be incurred. A raised lap seam and spot weld are used for attaching the collar to the body and no caulking is used. If caulking is required, additional cost may be incurred. 14ga and 12ga - Collars have a plasma welded longitudinal seam

Optional End Types

Standard QF end can be changed to Raw ID (RI), Raw OD (RO), No Fitting (NF), Hose Adapter (RF), Flat Flange (FFL), Angle Flange (AFL), or Van Stone (VS).

Y Branch

Ordering Information

- When ordering, specify material, gauge (if non-standard), dimensions A, B, C, end types, and angle (standard 60°, optional 90°).
- Both B & C each must be at least 50% of A, with B or C being at least 80% of the opposite leg.
- Flange Leg: Length = 4.5"
Height = A + 4"
- 14 Gauge Y Branches:**
- Any Branch with B, or C end smaller than 8" will be hybrid. (Smaller section will be a lighter gauge.)

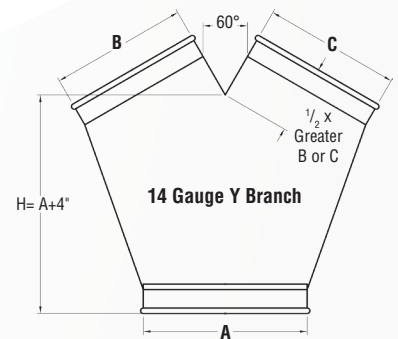
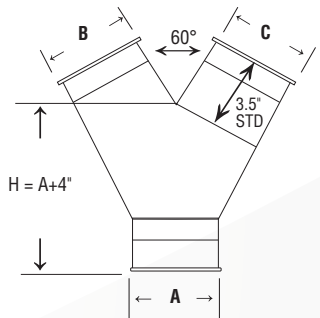
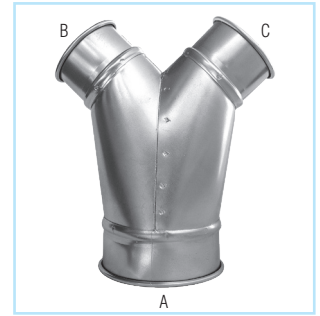

Please carefully note Nordfab Y Branch End Label designations (ABC)

Construction

Seam: Longitudinal seam is lapped, spot welded, and caulked on standard gauges. 14ga and 12ga - Solid butt welds.

Collars: Located on the exterior side of each port and considered as air flow non-directional. Collars have a laser welded longitudinal seam. If airflow directional product is required, it must be stated on the PO and additional cost may be incurred. A raised lap seam and spot weld are used for attaching the collar to the body and no caulking is used. If caulking is required, additional cost may be incurred. 14ga and 12ga - Collars have a plasma welded longitudinal seam.

Optional End Types

Standard QF end can be changed to Raw ID (RI), Raw OD (RO), No Fitting (NF), Hose Adapter (RF), Flat Flange (FLL), Angle Flange (AFL), or Van Stone (VS).

QF Material Options

		Galv			SS		
		Size (inches)			Size (inches)		
		Gauges	Min. Ø	Max. Ø	Gauges	Min. Ø	Max. Ø
Standard	22	3	12	Standard	22	3	12
	20	13	24		20	13	24
Optional	18	4	24	Optional	18	8	24
	16	8	24		16	8	24
	14	8	24				

Flanged Material Options

		Galv			SS		
		Size (inches)			Size (inches)		
		Gauges	Min. Ø	Max. Ø	Gauges	Min. Ø	Max. Ø
Standard	22	3	12	Standard	22	3	12
	20	13	24		20	13	24
	18	26	30		18	26	30
	16	32	40		16	32	40
	14	42	50		14	42	50
Optional	12	52	72	Optional	20	4	12
	20	4	12		18	8	24
	18	4	24		16	8	30
	16	8	30				
	14	8	50				
	12	10	72				
	10	12	72				

A Ø in.	Length in.	Weight Lbs
3		1.50
4		1.75
5	QF or Raw ends:	2.00
6	To manufacture,	2.75
7	B and C must be 50% or	3.25
8	greater of A;	4.50
9	B and C must be within	5.25
10	80% of each other.	6.75
11	Example: if B=10", then	8.00
12	C must be at least 8" or	10.25
13	greater.	12.50
14	Length =	14.00
15	A + 4"	15.75
16	14ga QF or Raw ends:	17.00
17	To manufacture,	18.50
18	B and C must be 50% or	20.00
19	greater of A;	24.50
20	B and C must be within	29.00
21	80% of	36.00
22	each other.	39.50
23	Example: if B=15", then	47.00
24	C must be at least 12" or	53.50
25	greater.	58.00
26	Length =	69.00
27	A + 4"	78.00
28		93.00
29		107.00
30	Angle Flange or	112.05
31	Flat Flange ends:	115.00
32	Flanged ends:	120.94
33	B or C ports leg length is	124.00
34	4.5" min.	129.83
35	14ga or 12ga with	133.00
36	Flanged ends:	137.78
37	B or D ports leg length is	143.00
38	1/2 greater of B or D	148.47
39		152.00
40		157.81

Double Branch

Ordering Information

- When ordering, specify material, gauge (if non-standard), dimensions A, B, C, D, end types, and angle (standard 30°, optional 45°).
- $(A - C) \geq (C - B)$ and $(C) \geq (D)$
- Use formula above to determine if a reducer is needed at C or D.

14 Gauge Branches:

- Any Branch with B, C or D end smaller than 8" will be hybrid. (Smaller section will be a lighter gauge.)



A Ø in.	Length in.	Weight Lbs
3		2.6
4		3.5
5		4.4
6		5.0
7		6.0
8		7.3
9		8.5
10	QF or Raw ends:	10.0
11		10.8
12	To manufacture, A - C must be greater to or equal to C - B and C must be greater than or equal to D.	12.3
13		13.2
14		15.0
15		17.4
16	Length = $C \times 2 + 9"$	19.6
17		21.0
18		26.0
19		35.0
20		49.5
21		68.4
22		39.5
23		47.0
24		53.5
25		94.0
26		104.0
27		116.0
28		128.0
29	Angle Flange or Flat Flange ends:	140.5
30		153.0
31	To manufacture, A - C must be greater to or equal to C - B and C must be greater than or equal to D.	158.0
32		165.0
33		171.0
34		180.0
35	Length = $C \times 2 + 15"$	184.0
36		188.0
37		195.0
38		203.5
39		212.0
40		223.0

QF Material Options

		Galv			SS		
		Size (inches)			Size (inches)		
Gauges		Min. Ø	Max. Ø	Gauges	Min. Ø	Max. Ø	
Standard	22	3	12	Standard	22	3	12
	20	13	24		20	13	24
Optional	18	4	24	Optional	18	8	24
	16	8	24		16	8	24
	14	8	24				

Flanged Material Options

		Galv			SS		
		Size (inches)			Size (inches)		
Gauges		Min. Ø	Max. Ø	Gauges	Min. Ø	Max. Ø	
Standard	22	3	12	Standard	22	3	12
	20	13	24		20	13	24
	18	26	30		18	26	30
	16	32	40		16	32	40
	14	42	50		14	42	50
Optional	12	52	72	Optional	20	4	12
	20	4	12		18	8	24
	18	4	24		16	8	30
	16	8	30				
	14	8	50				
	12	10	72				
	10	12	72				

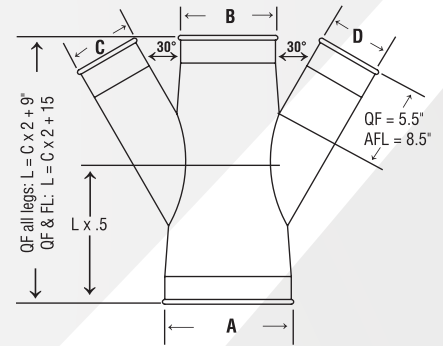

Please carefully note Nordfab Double Branch End Label designations (ABCD)

Construction

Seam: Longitudinal seam is lapped, spot welded, and caulked on standard gauges. 14ga and 12ga - Solid butt welds.

Collars: Located on the exterior side of each port and considered as air flow non-directional. Collars have a laser welded longitudinal seam. If airflow directional product is required, it must be stated on the PO and additional cost may be incurred. A raised lap seam and spot weld are used for attaching the collar to the body and no caulking is used. If caulking is required, additional cost may be incurred. 14ga and 12ga - Collars have a plasma welded longitudinal seam

Optional End Types

Standard QF end can be changed to Raw ID (RI), Raw OD (RO), No Fitting (NF), Hose Adapter (RF), Flat Flange (FFL), Angle Flange (AFL), or Van Stone (VS).

Tee Branch

Ordering Information

- When ordering, specify material, gauge (if non-standard), dimensions A and C, and end types.
- Both A ends must be the same dimension; C must be equal to or smaller than the A dimension.

14 Gauge:

- Any 14ga Branch with an end smaller than 8" will be hybrid. (Smaller section will be a lighter gauge.)

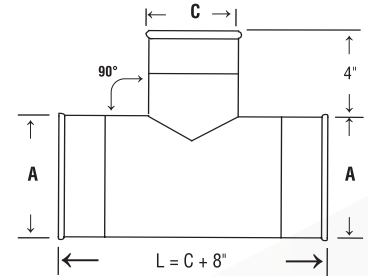
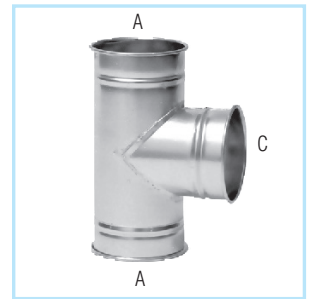

Please carefully note Nordfab Tee Branch End Label designations (A and C)

A Ø in.	Length in.	Weight Lbs
3		1.5
4		2.0
5		2.8
6		3.3
7		4.0
8		4.8
9		5.5
10		6.0
11		7.5
12		8.8
13		10.3
14		12.0
15		13.3
16		14.0
17		16.0
18		18.3
19		19.5
20	To manufacture, A must be same diameter straight through; C must be equal to or less than A	20.5
21		22.0
22	Length = C + 8"	24.8
23		27.0
24		29.0
25		34.5
26		40.3
27		43.0
28		45.0
29		52.0
30		58.5
31		61.0
32		63.0
33		65.0
34		66.4
35		68.2
36		70.3
37		72.5
38		75.7
39		77.4
40		80.4

QF Material Options

Galv				SS			
Gauges	Size (inches)		Gauges	Size (inches)			
	Min. Ø	Max. Ø		Min. Ø	Max. Ø		
Standard	22	3	12	22	3	12	
	20	13	24	20	13	24	
Optional	18	4	24	18	8	24	
	16	8	24	16	8	24	
	14	8	24				

Flanged Material Options

Galv				SS			
Gauges	Size (inches)		Gauges	Size (inches)			
	Min. Ø	Max. Ø		Min. Ø	Max. Ø		
Standard	22	3	12	22	3	12	
	20	13	24	20	13	24	
	18	26	30	18	26	30	
	16	32	40	16	32	40	
	14	42	50	20	4	12	
Optional	12	52	72	18	8	24	
	20	4	12	16	8	30	
	18	4	24				
	16	8	30				
	14	8	50				
	12	10	72				
	10	12	72				

Construction

Seam: Longitudinal seam is lapped, spot welded, and caulked on standard gauges. 14ga and 12ga - Solid butt welds.

Collars: Located on the exterior side of each port and considered as air flow non-directional. Collars have a laser welded longitudinal seam. If airflow directional product is required, it must be stated on the PO and additional cost may be incurred. A raised lap seam and spot weld are used for attaching the collar to the body and no caulking is used. If caulking is required, additional cost may be incurred. 14ga and 12ga - Collars have a plasma welded longitudinal seam.

Optional End Types

Standard QF end can be changed to Raw ID (RI), Raw OD (RO), No Fitting (NF), Hose Adapter (RF), Flat Flange (FLL), Angle Flange (AFL), or Van Stone (VS).

In-Cut

Ordering Information

- When ordering, specify material, gauge (if non-standard), dimensions A and C, C end type, and angle (standard 30°, optional 45°).
- In-cut used to cut into existing lines to begin QF system.

14 Gauge:

- Any Branch with end smaller than 8" will be hybrid. (Smaller section will be a lighter gauge.)

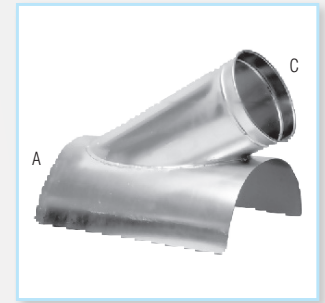

C Ø in.	Weight Lbs
3	1.3
4	1.5
5	2.2
6	2.8
7	3.5
8	4.5
9	5.4
10	6.5
11	7.6
12	8.8
13	11.2
14	13.9
15	15.8
16	17.2
17	19.3
18	21.3
19	23.3
20	25.6
21	27.8
22	30.5
23	33.0
24	35.4
25	37.8
26	40.3
27	42.5
28	45.0
29	50.5
30	56.5
31	59.8
32	63.0
33	63.8
34	67.4
35	69.5
36	71.4
37	73.8
38	76.8
39	79.0
40	81.4

QF Material Options

Galv				SS			
Gauges	Size (inches)			Gauges	Size (inches)		
	Min. Ø	Max. Ø			Min. Ø	Max. Ø	
Standard	22	3	12	Standard	22	3	12
	20	13	24		20	13	24
Optional	18	4	24	Optional	18	8	24
	16	8	24		16	8	24
	14	8	24				

Flanged Material Options

Galv				SS			
Gauges	Size (inches)			Gauges	Size (inches)		
	Min. Ø	Max. Ø			Min. Ø	Max. Ø	
Standard	22	3	12	Standard	22	3	12
	20	13	24		20	13	24
	18	26	30		18	26	30
	16	32	40		16	32	40
	14	42	50		20	4	12
	12	52	72		18	8	24
Optional	20	4	12	Optional	16	8	30
	18	4	24				
	16	8	30				
	14	8	50				
	12	10	72				
	10	12	72				

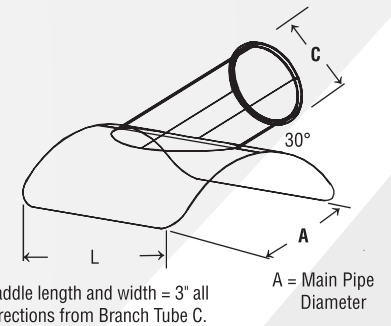

Please carefully note Nordfab In-Cut End Label designations (A and C)

Construction

Seam: Longitudinal seam is lapped, spot welded, and caulked.

Collars: Located on the exterior side of each port and considered as air flow non-directional. Collars have a laser welded longitudinal seam. If airflow directional product is required, it must be stated on the PO and additional cost may be incurred. A raised lap seam and spot weld are used for attaching the collar to the body and no caulking is used. If caulking is required, additional cost may be incurred.

Optional C End Types

Standard QF end can be changed to Raw ID (RI), Raw OD (RO), No Fitting (NF), Hose Adapter (RF), Flat Flange (FFL), Angle Flange (AFL), or Van Stone (VS).

Tap In

Ordering Information

- When ordering, specify material, gauge (if non-standard), dimensions A and C, and C end type.
- Tap In is used to cut into existing lines to begin QF system.

14 Gauge:

- Any Branch with end smaller than 8" will be hybrid. (Smaller section will be a lighter gauge.)

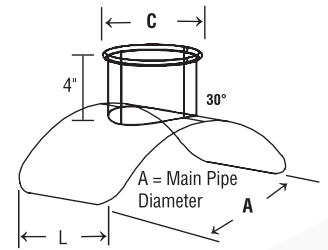
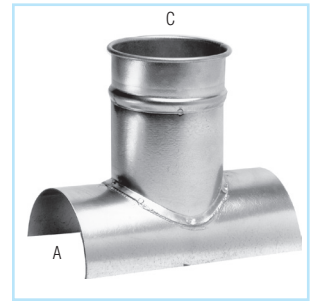

Saddle length and width = 3" all directions from Branch Tube C

Please carefully note Nordfab Tap In End Label designations (A and C)

Construction

Seam: Longitudinal seam is lapped, spot welded, and caulked.

Collars: Located on the exterior side of each port and considered as air flow non-directional. Collars have a laser welded longitudinal seam. If airflow directional product is required, it must be stated on the PO and additional cost may be incurred. A raised lap seam and spot weld are used for attaching the collar to the body and no caulking is used. If caulking is required, additional cost may be incurred.

Optional C End Types

Standard QF end can be changed to Raw ID (RI), Raw OD (RO), No Fitting (NF), Hose Adapter (RF), Flat Flange (FFL), Angle Flange (AFL), or Van Stone (VS).

A Ø in.	Length in.	Weight Lbs
3		0.5
4		0.6
5		0.8
6		1.1
7		1.4
8		1.6
9		1.9
10		2.7
11		2.5
12		2.9
13		3.3
14		4.4
15		5.1
16		5.6
17		6.1
18		6.7
19		7.3
20		7.7
21	Saddle length and width = 3" all directions from Branch Tube C	8.1
22		8.9
23		9.2
24		11.3
25		23.3
26		35.3
27		37.5
28		40.0
29		45.5
30		51.5
31	54.8	
32	58.0	
33	59.5	
34	62.4	
35	64.5	
36	66.8	
37	69.0	
38	71.7	
39	75.5	
40	79.4	

QF Material Options

Galv				SS			
		Size (inches)				Size (inches)	
Gauges	Min. Ø	Max. Ø	Gauges	Min. Ø	Max. Ø	Gauges	Max. Ø
Standard	22	3	12	Standard	22	3	12
	20	13	24		20	13	24
Optional	18	4	24	Optional	18	8	24
	16	8	24		16	8	24
	14	8	24				

Flanged Material Options

Galv				SS			
		Size (inches)				Size (inches)	
Gauges	Min. Ø	Max. Ø	Gauges	Min. Ø	Max. Ø	Gauges	Max. Ø
Standard	22	3	12	Standard	22	3	12
	20	13	24		20	13	24
	18	26	30		18	26	30
	16	32	40		16	32	40
	14	42	50		20	4	12
Optional	12	52	72	Optional	18	8	24
	20	4	12		16	8	30
	18	4	24				
	16	8	30				
	14	8	50				
	12	10	72				
	10	12	72				

Reducer

Ordering Information

- When ordering, specify material, gauge (if non-standard), A,B dimensions and end types.
 - B end can be as small as 1".
- 14 Gauge Reducers:**
Any Reducer with B end smaller than 8" will be hybrid. Smaller section will be a lighter gauge.

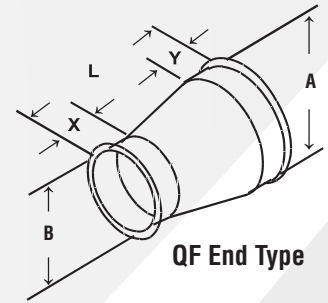
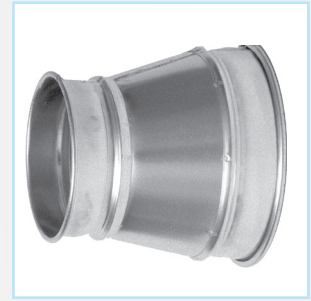

AØ in.	Length in.	Weight Lbs
3		1.00
4		1.25
5		1.50
6		1.75
7		2.00
8		2.25
9		2.50
10		3.00
	A-B Δ Formula	
11	1-6 A-B+6	3.50
12	7-12 A-B+8	3.75
13	13+ A-B+10	4.00
14	Ex: A=8" B=6" Reducer, A-B= 2, therefore Δ=2, so you will use the first formula since the difference is between 1-6 A-B+6= 8" Length	4.50
15		6.00
16		7.00
17		10.25
18		21.00
19		25.00
20		30.00
21		35.00
22		39.50
23		47.00
24	53.50	
	A-B Δ Formula	
26	1-6 A-B+7	74.00
28	7-12 A-B+9	98.00
30	13+ A-B+11	117.05
32		125.94
34	Ex: A=36" B=28" Reducer, A-B= 8, therefore Δ=8, so you will use the second formula since the difference is between 7-12 A-B+9= 17" Length	134.83
36		142.78
38		153.47
40		162.81

QF Material Options

		Galv			SS		
		Size (inches)			Size (inches)		
	Gauges	Min. Ø	Max. Ø	Gauges	Min. Ø	Max. Ø	
Standard	22	3	12	Standard	22	3	12
	20	13	24		20	13	24
Optional	18	4	24	Optional	18	8	24
	16	8	24		16	8	24
	14	8	24				

Flanged Material Options

		Galv			SS		
		Size (inches)			Size (inches)		
	Gauges	Min. Ø	Max. Ø	Gauges	Min. Ø	Max. Ø	
Standard	22	3	12	Standard	22	3	12
	20	13	24		20	13	24
	18	26	30		18	26	30
	16	32	40		16	32	40
	14	42	50		20	4	12
	12	52	72		18	8	24
Optional	20	4	12	Optional	16	8	30
	18	4	24				
	16	8	30				
	14	8	50				
	12	10	72				
	10	12	72				

Construction
Seam: longitudinal seam is lapped, spot welded, and caulked.
Collars: located on the exterior side of each port and considered as air flow non-directional. Collars have a laser welded longitudinal seam. If air flow directional product is required, it must be stated on the PO and additional cost may be incurred. A raised lap seam and spot weld are used for attaching the collar to the body and no caulking is used. If caulking is required, additional cost may be incurred.

Optional End Types
 Standard QF end can be changed to Raw ID (RI), Raw OD (RO), No Fitting (NF), Hose Adapter (RF) only on sizes 3" and above, Flat Flange (FFL), Angle Flange (AFL), or Van Stone (VS). Any combination of these end types are available upon request.

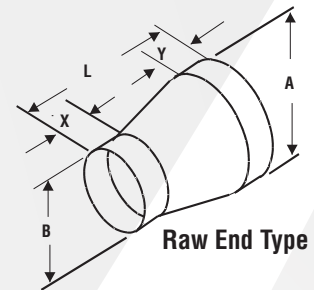
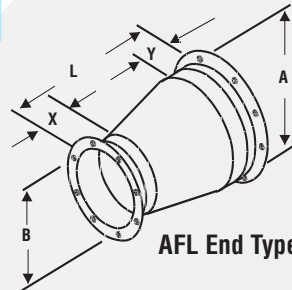

Describe your Reducer requirements										
Qty	Material	A	End Type	B	End Type	L	X STD-2"	Y STD-2"	Flange Dwg	Notes

Angle Flange Adapter

Ordering Information

- When ordering, specify material, gauge (if non-standard), dimension and end types (AFL for Angle Flange or FFL for Flat Flange).
- Adapts duct with QF ends to duct with flanged ends.
- Adapter length can be adjusted.
- Angle Flange is supplied as standard. Angle Flange is retained via 3/8" Vanstone lip. Angle Flange is rotational for easier installation.
- Flat Flange: Specify hole pattern. (Cost same as Angle Flange). If no hole pattern drawing provided, flat flange will be blank.
- If welded flanges requested, clocked location must be specified.
- Reference Angle Flange for dimensions and hole pattern.

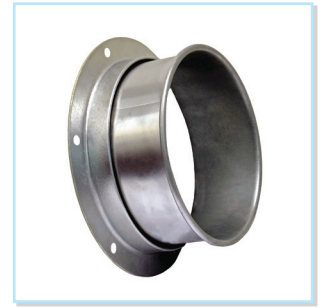

Ø in.	Length in.	Std Weight Lbs
3	5	1.40
4	3.5	1.70
5		2.15
6		2.55
7		3.10
8		3.15
9		3.25
10		5.00
11		5.60
12		6.15
13		7.02
14	7.70	
15	9.25	
16	11.05	
17	12.90	
18	15.20	
19	19.15	
20	19.15	
21	26.05	
22	26.05	
23	30.00	
24	30.00	

QF Material Options

Galv				SS			
Gauges	Size (inches)			Gauges	Size (inches)		
	Min. Ø	Max. Ø			Min. Ø	Max. Ø	
Standard	22	3	12	Standard	22	3	12
	20	13	24		20	13	24
Optional	18	4	24	Optional	18	8	24
	16	8	24		16	8	24
	14	8	24		16	8	24

Flanged Material Options

Galv (Std)				SS			
Gauges	Size (inches)			Gauges	Size (inches)		
	Min. Ø	Max. Ø			Min. Ø	Max. Ø	
Standard	22	3	12	Standard	22	3	12
	20	13	40		20	13	40
Optional	18	4	40	Optional	18	8	40
	16	8	40		16	8	40
	14	8	50				
	12	10	72				

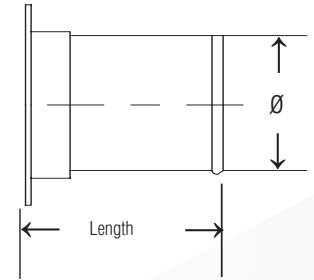

Construction

Seam: Longitudinal seam is laser welded.

Optional End Types

Standard QF end can be changed to Raw ID (RI), Raw OD (RO), No Fitting (NF), Hose Adapter (RF), Flat Flange (FFL), Angle Flange (AFL), or Van Stone (VS). Angle flanged (AF) end can be modified to a 3/16" thick flat flange (FFL) to match your hole pattern.

*Published lengths are nominal and may vary slightly.

Machine Adapter

Ordering Information

- When ordering, specify material, gauge (if non-standard), dimension and end types. Standard end types are QF to NOFIT.
- If Expanded, specify desired ID or OD of non QF end. **Must be within maximum opened dimension (.3"), or will be priced as reducer.**

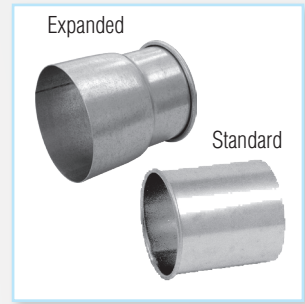

Ø in.	Length in.	Raw End ID in.	Raw End OD in.	Max. Open Dim ID in.	Std Weight Lbs
3	5.5	3.03	3.10	3.18	0.60
4	4	3.86	3.93	4.30	0.75
5		4.87	4.94	5.30	0.95
6		5.89	5.96	6.30	1.10
7		6.89	6.96	7.30	1.35
8		7.88	7.95	8.30	1.50
9		8.89	8.95	9.30	1.75
10		9.89	9.95	10.30	1.95
11		10.88	10.94	11.30	2.10
12		11.97	12.04	12.30	2.30
13		5.5	12.97	13.05	13.30
14	13.96		14.04	14.30	2.70
15	14.96		15.04	15.30	3.05
16	15.97		16.04	16.30	3.20
17	16.97		17.05	17.30	3.32
18	17.96		18.04	18.30	3.45
19	18.96		19.04	19.30	3.68
20	19.96		20.04	20.30	3.90
21	20.97		21.05	21.30	4.10
22	21.97		22.05	22.30	4.30
23	22.97		23.05	23.30	4.95
24	23.94		24.02	24.30	5.60

QF Material Options

Galv				SS				
Gauges	Size (inches)		Gauges	Size (inches)				
	Min. Ø	Max. Ø		Min. Ø	Max. Ø			
Standard	22	3	12	Standard	22	3	12	
	20	13	24		20	13	24	
Optional	18	4	24	Optional	18	8	24	
	16	8	24		Optional	16	8	24
	14	8	24					

Flanged Material Options

Galv (Std)				SS				
Gauges	Size (inches)		Gauges	Size (inches)				
	Min. Ø	Max. Ø		Min. Ø	Max. Ø			
Standard	22	3	12	Standard	22	3	12	
	20	13	40		20	13	40	
Optional	18	4	40	Optional	18	8	40	
	16	8	40		Optional	16	8	40
	14	8	50					
	12	10	72					

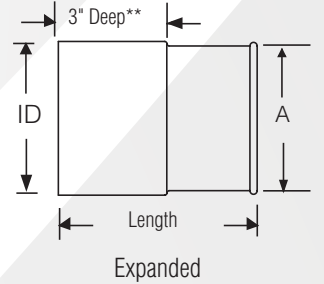
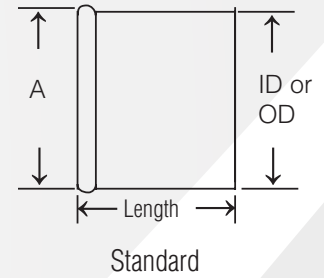

Adapters can only be expanded up to .3" above the nominal diameter size (A dimension). Expansions larger than .3" must be ordered as a reducer.

*Published lengths are nominal and may vary slightly.

Hose Adapter

Ordering Information

- When ordering, specify material, gauge (if non-standard), dimension and end types. Standard end types are QF to RAWFLEX.
- Connects to Rubber Hose. Not compatible with metal flex hose.

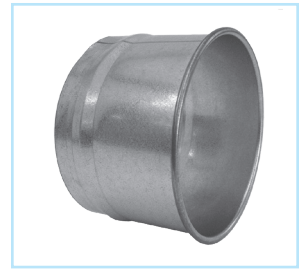

Ø in.	Length in.	Std Weight Lbs
3	5.5	0.60
4	4.0	0.75
5	4.0	0.95
6	4.0	1.10
7	4.0	1.35
8	4.0	1.50
9	4.0	1.75
10	4.0	1.95
11	4.0	2.10
12	4.0	2.30
13	5.5	2.45
14	5.5	2.70
15	5.5	3.05
16	5.5	3.20
17	5.5	3.32
18	5.5	3.45
19	5.5	3.68
20	5.5	3.90
21	5.5	4.10
22	5.5	4.30
23	5.5	4.95
24	5.5	5.60

QF Material Options

Galv				SS		
Gauges	Size (inches)		Gauges	Size (inches)		
	Min. Ø	Max. Ø		Min. Ø	Max. Ø	
Standard	22	3	12	22	3	12
	20	13	24	20	13	24
Optional	18	4	24	18	8	24
	16	8	24	16	8	24

Flanged Material Options

Galv (Std)				SS		
Gauges	Size (inches)		Gauges	Size (inches)		
	Min. Ø	Max. Ø		Min. Ø	Max. Ø	
Standard	22	3	12	22	3	12
	20	13	40	20	13	40
Optional	18	4	40	18	8	40
	16	8	40	16	8	40
	14	8	50			
	12	10	72			

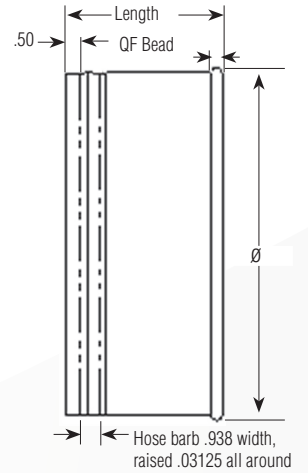

Construction

Seam: Longitudinal seam is solid laser welded.

Optional End Types

Standard QF end can be changed to Raw ID (RI), Raw OD (RO), No Fitting (NF), Flat Flange (FFL), Angle Flange (AFL), or Van Stone (VS).

*Published lengths are nominal and may vary slightly.

Transition Rectangular to Round

Ordering Information

- When ordering, specify material, gauge (if non-standard), round end \varnothing , square end H and W dimensions, and end types. Also specify desired length.
- L must be at least 75% of W or transition will be Square to Square.
- L of Square to Round (at least 7" minimum).
- L of Square to Square (4" minimum).



QF & Flanged Material Gauges

Standard metal thickness is based on square end opening

Standard Metal Thickness (ga)	Square End Opening SqIn (in ²)
22	16-144
20	145-324
18	325-576
16	577-1296
14	1297-2304
12	2305-3600
10	3601-22500

Ex: 12"QF to 24"x36"RawID Transition, so the square end opening is $24 \times 36 = 864 \text{ in}^2$ which falls in the 577-1296 range; therefore, the metal thickness is 16 gauge.

Construction

Seam: longitudinal seam is lapped, spot welded, and caulked.

Collars: located on the exterior side of each port and considered as air flow non-directional. Collars have a laser welded longitudinal seam. If air flow directional product is required, it must be stated on the PO and additional cost may be incurred. A raised lap seam and spot weld are used for attaching the collar to the body and no caulking is used. If caulking is required, additional cost may be incurred.

Optional End Types

Standard QF end can be changed to Raw ID (RI), Raw OD (RO), No Fitting (NF), Hose Adapter (RF), Flat Flange (FFL), Angle Flange (AFL), or Van Stone (VS).

Rectangular / square end standard options are Raw, Hemmed, Angle Flange (AFL), Sheet Metal Flange (SMFL), or Flat Flange (FFL).

Notes

Additional costs for flanges. Prices are determined by the rectangular dimensions, with adder for flange(s) if needed. If flange other than Angle Flange is requested and no hole pattern is supplied, flange will be supplied "blank" to be field drilled.

Standard flange material is $1\frac{1}{2} \text{ W} \times \frac{3}{16} \text{ THK}$ angle. Transition diameter sizes exceeding 24" will be supplied with a flanged round end.

Rectangular to Round

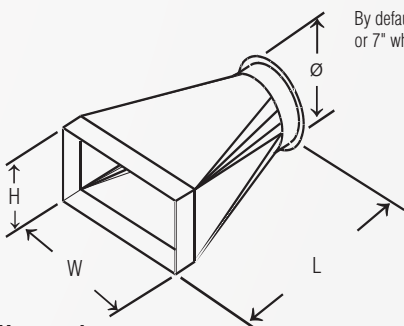

Hemmed or Raw Rectangular End Type

By default, $L=W$ (min. $L=W \times 0.75$ or 7" whichever is greater)

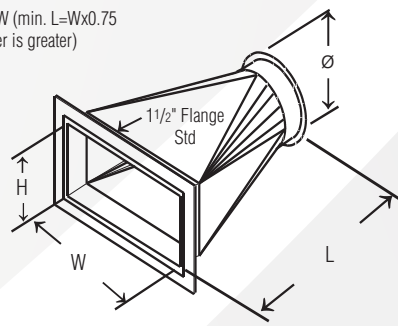

Flanged Rectangular End Type

Square to Square

By default, $L=W$ (min. 4")

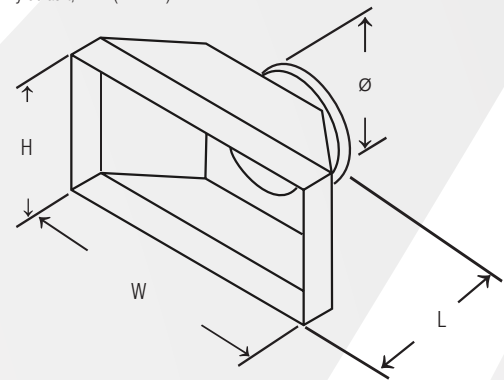

Describe your Transition requirements

Qty	Material	Gauge	\varnothing	End Type	H	W	End Type	L	Flange Dwg	Notes

End Cap | End Cap with Birdscreen | End Plate

Ordering Information

- When ordering, specify material, gauge (if non-standard), dimension and end types. Standard End Cap end types are QF to flat plate. Standard End Cap with Birdscreen end types are QF to 1/2" square wire mesh screen (larger than 24" will have expanded metal screen).
- End Cap enables users to close off taps for future use.
- End Cap larger than 24" will be constructed of flat plate and Angle Flange.
- Wire mesh on End Cap with Bird Screen can be replaced with perforated metal.

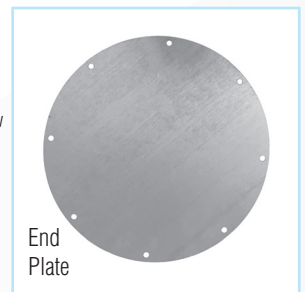

Ø in.	Length in.	QF End Cap Std Weight Lbs	QF End Cap w/ Birdscreen Weight Lbs
3	2.25	0.30	.25
4	2.25	0.37	.30
5	2.25	0.50	.35
6	2.25	0.72	.52
7	2.00	0.92	.60
8	2.00	1.10	.70
9	2.00	1.40	.80
10	2.00	1.65	.90
11	2.00	1.85	.95
12	1.88	2.05	1.00
13	1.88	2.45	1.15
14	1.88	3.10	1.25
15	1.88	3.55	1.36
16	1.88	4.00	1.48
17	1.88	4.45	1.60
18	1.88	4.90	1.75
19	1.88	5.20	1.82
20	1.88	5.45	1.90
21	1.88	5.90	2.00
22	1.88	6.30	2.10
23	1.88	7.10	2.45
24	1.88	7.90	2.85

*Published lengths are nominal and may vary slightly.

QF Material Options

		Galv			SS		
		Size (inches)			Size (inches)		
		Gauges	Min. Ø	Max. Ø	Gauges	Min. Ø	Max. Ø
Standard	22	3	12	Standard	22	3	12
	20	13	24		20	13	24
Optional	18	4	24	Optional	18	8	24
	16	8	24		16	8	24
	14	8	24				

Flanged Material Options

		Galv (Std)			SS		
		Size (inches)			Size (inches)		
		Gauges	Min. Ø	Max. Ø	Gauges	Min. Ø	Max. Ø
Standard	22	3	12	Standard	22	3	12
	20	13	24		20	13	24
	18	26	30		18	26	30
	16	32	40		16	32	40
	14	42	50		20	4	12
Optional	12	52	72	Optional	18	8	24
	20	4	12		16	8	30
	18	4	24				
	16	8	30				
	14	8	50				
	12	10	72				
	10	12	72				

Construction

Collar seam: Longitudinal seam is solid laser welded.

Flanged End Cap with Birdscreen: expanded metal welded to Angle Flange.

End Plate: Solid end plate is crimped in place, similar to a lockform seam.

Optional End Types

Standard QF end can be changed to Raw ID (RI), Raw OD (RO), No Fitting (NF), Flat Flange (FFL), Angle Flange (AFL), or Van Stone (VS).

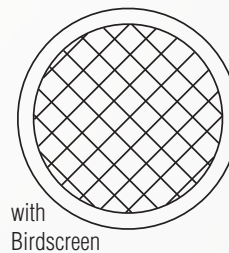
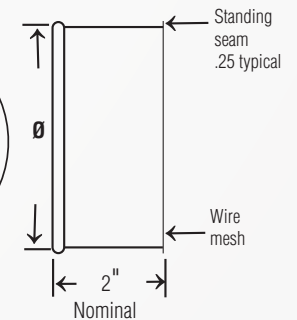
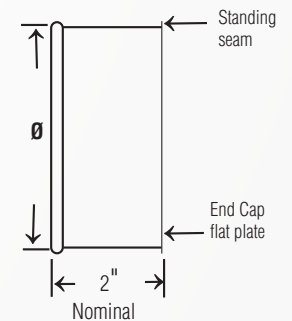

Manual Blast Gate

Ordering Information

- When ordering, specify material, gauge (if non-standard), dimension and end types.

- Standard Blast Gates are cast aluminum body with galvanized blade and standard QF connection (collar), unless otherwise specified. SS model is 100% SS, body and blade are 12ga. 14ga Blast Gate is 10ga galvanized steel with a 14ga collar.



Ø in.	Galvanized					Std Weight Lbs
	A Height Closed in.	B Height Opened in.	C Width in.	D Depth Opened in.	E in.	
3	7.50	8.50	4.25	5.38	1.63	1.50
4	6.75	9.75	5.13	5.50	2.25	2.25
5	8.00	11.75	5.88	5.63	2.63	3.00
6	10.00	14.50	7.00	5.75	3.00	3.75
7	11.13	15.25	8.00	5.50	3.75	4.50
8	12.00	18.63	9.25	5.50	4.25	5.50
9	13.38	20.25	10.50	5.50	5.13	7.00
10	14.50	23.38	11.25	5.50	5.25	7.50
11	15.25	25.50	12.25	5.50	6.00	9.50
12	16.25	27.50	13.25	5.00	6.88	13.00
14	18.63	30.50	15.50	5.00	7.63	16.00
16	28.50	43.50	18.00	11.25	8.88	21.20
18	32.50	32.50	20.00	11.25	9.88	25.00
20	33.88	33.88	22.25	11.25	10.50	30.00
22	33.50	33.50	24.25	11.25	11.13	34.00
24	33.38	33.38	26.25	11.25	12.25	38.00
26	47.50	70.50	29.25	11.25	13.25	62.00
28	47.50	73.50	30.25	11.25	14.25	72.00
30	55.75	82.75	33.25	11.25	15.25	97.00

Ø in.	Stainless Steel		14ga Galv (8" & larger)			
	A Height Closed in.	B Height Opened in.	C Width in.	D Depth in.	E in.	
3	6.00	10.00	5.00	5.00	3.00	
4	7.50	12.50	6.00	5.375	3.75	
5	9.00	15.00	7.00	5.375	4.50	
6	10.5	17.50	8.00	5.50	5.25	
7	13.00	21.00	9.00	5.25	6.50	
8	13.50	22.50	10.00	5.125	6.75	
9	15.00	25.00	11.00	5.00	7.50	
10	16.50	27.50	12.00	5.125	8.25	
11	18.00	30.00	13.00	5.50	9.00	
12	19.50	32.50	14.00	4.875	9.75	
14	22.50	37.50	16.00	4.875	11.25	
16	25.50	42.50	18.00	4.75	12.75	
18	28.50	47.50	20.00	4.75	14.25	
20	31.50	52.50	22.00	4.75	15.75	
22	34.50	57.50	24.00	4.75	17.25	
24	37.50	62.50	26.00	4.75	18.75	
26	41.25	60.75	28.00	5.75	14.00	
28	44.25	64.75	30.00	5.75	15.00	
30	47.25	68.75	32.00	5.75	16.00	

QF Material Options

Galv (Collar)				SS (Collar)			
Gauges	Size (inches)		Gauges	Size (inches)			
	Min. Ø	Max. Ø		Min. Ø	Max. Ø		
Standard	22	3	12	Standard	22	3	12
	20	14	24		20	14	24
Optional	18	3	24	Optional	18	8	24
	16	8	24		16	8	24
	14	8	24				

SS Blast Gates have a production time of 7 days min.

Flanged Material Options

Galv (Collar)				SS (Collar)			
Gauges	Size (inches)		Gauges	Size (inches)			
	Min. Ø	Max. Ø		Min. Ø	Max. Ø		
Standard	22	3	12	Standard	22	3	12
	20	14	24		20	14	24
	18	26	40		18	26	30
Optional	18	3	24	Optional	18	8	24
	16	8	24		16	8	24
	14	8	30				

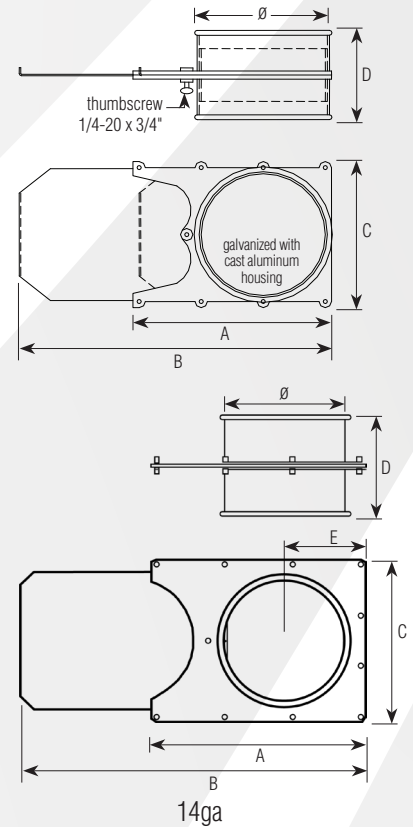

Construction

Collars: Attached to the exterior on each side of the cast aluminum body of each standard galvanized Gate. 16" and larger diameter Blast Gates have riveted-on collars. SS Blast Gates have collars fully welded to the SS body.

Optional End Types

Standard QF end can be changed to Raw ID (RI), Raw OD (RO), No Fitting (NF), Flat Flange (FFL), Angle Flange (AFL), or Van Stone (VS).

SS Blast Gates have a production time of **7 business days** minimum

Blast Gate NFMES

Ordering Information

- When ordering, specify material, gauge (if non-standard), dimension and end types.
- Manually operated, energy saving blast gates. Compact and easy to operate. Special sealing device reduces air loss and friction in operation.

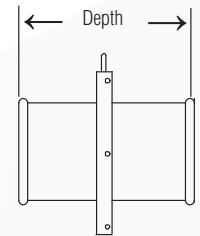
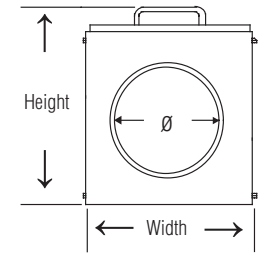
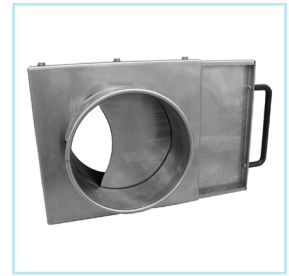

Construction
Blade and body: 18 gauge
Collars: Located on the exterior side of each port and considered as air flow non-directional. Collars have a laser welded longitudinal seam. Collars are spot welded to body.
Handles: 1018 carbon steel Powder Coated
Optional End Types: Standard QF end can be changed to Raw ID (RI), Raw OD (RO), No Fitting (NF), Hose (RF), Flat Flange (FFL), Angle Flange (AFL), or Van Stone (VS).

Ø in	Height Closed in.	Width in.	Depth Opened in.	Std Weight Lbs
3	7.00	5.25	5.38	
4	6.25	6.12	5.38	2.70
5	10.00	7.00	5.00	3.30
6	11.12	8.00	5.00	5.90
7	12.00	9.37	5.00	6.00
8	13.25	11.00	5.00	6.75
9	14.37	11.37	5.00	7.50
10	16.25	13.50	5.00	9.12
12	17.87	15.75	5.00	13.00
14	28.50	18.00	5.00	18.25
16	28.50	18.00	5.00	21.50

QF Material Options

Galv (Collar)				SS (Collar)			
Gauges	Size (inches)		Gauges	Size (inches)			
	Min. Ø	Max. Ø		Min. Ø	Max. Ø		
Standard	22	3	12	Standard	22	3	12
	20	14	16		20	14	16
Optional	18	3	16	Optional	18	8	16
	16	8	16		16	8	16
	14	8	16		◇ SS Blast Gates have a production time of 7 days min.		

Flanged Material Options

Galv (Collar)				SS (Collar)			
Gauges	Size (inches)		Gauges	Size (inches)			
	Min. Ø	Max. Ø		Min. Ø	Max. Ø		
Standard	22	3	12	Standard	22	3	12
	20	14	16		20	14	16
Optional	18	3	16	Optional	18	8	16
	16	8	16		16	8	16
	14	8	16				



Temperature Rating: Max. temperature limited to 250°F due to properties of the gasket material (High Density Polyethylene - HDPE).

SS Blast Gates have a production time of **7 business days** minimum

Blast Gate NFES Automatic

Ordering Information

- When ordering, specify material, gauge (if non-standard), dimension, end types and control circuit voltage.
- Automatic energy saving blast gates operated by compressed air cylinders. Cylinders are controlled by electrically-connected solenoid to machines or remote switch. Special sealing device reduces air loss and friction in operation.

- APPLICATION: Gates are used as energy saving devices for industrial dust extraction where continuous extraction is not always needed and where manual control needs to be eliminated.
- Standard 120V control circuit and 75psi minimum air pressure. Optional 24V DC or AC control circuit available.
- All auto blast gates have cylinders with galvanized or SS body and steel rod. Single cylinder: 3" to 8". Double cylinder 9" to 22". Solenoid has plastic housing.

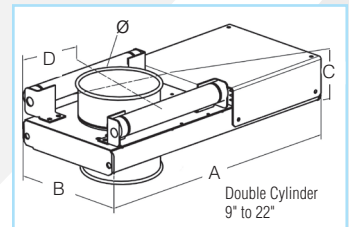
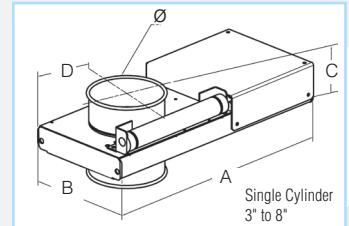
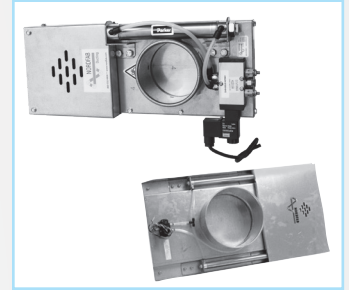

All cylinders are magnetic.

Ø in.	Galvanized				Std Weight Lbs
	A in.	B in.	C in.	D in.	
3	16.0	6.38	5.50	5.50	9.83
4	16.0	6.30	5.50	5.11	9.90
5	17.5	7.50	5.25	6.00	11.90
6	20.5	8.66	5.25	7.00	15.15
7	22.0	9.44	5.25	7.25	18.85
8	25.5	10.25	5.25	8.25	27.50
9	33.0	17.36	9.00	14.17	37.50
10	33.0	17.36	9.00	14.17	37.50
12	38.5	20.00	9.00	15.50	44.00
14	41.0	23.30	12.00	16.00	50.00
16	45.0	23.30	12.00	17.12	63.00
18	48.5	25.25	12.00	18.00	74.00
20	52.5	27.20	12.00	19.00	83.00
22	57.5	29.50	12.00	20.27	104.00

QF Material Options

Gauges	Galv Collar		Gauges	SS		
	Size (inches)			Size (inches)		
	Min. Ø	Max. Ø		Min. Ø	Max. Ø	
Standard	22	3	12	22	3	12
	20	14	22	20	14	22
Optional	18	3	22	18	8	22
	16	8	22	16	8	22
	14	8	22	◇ SS Blast Gates have a production time of 7 days min.		

Flanged Material Options

Gauges	Galv Collar		Gauges	SS		
	Size (inches)			Size (inches)		
	Min. Ø	Max. Ø		Min. Ø	Max. Ø	
Standard	22	3	12	22	3	12
	20	14	22	20	14	22
Optional	18	3	22	18	8	22
	16	8	22	16	8	22
	14	8	22	16	8	22

Temperature Rating: Max. temperature limited to 120°F unless solenoids are located outside of housing. Max temperature for the Poly tubing on the outside of the housing is 150°F unless carefully located. Gasket Spring (Poron Cellular Urethane) max. temp. is continuous 158°F, intermittent to 250°.

◇ SS Blast Gates have a production time of **7 business days** minimum. Larger Blast Gates may also take longer than standard lead time.

Optional Reed Switch available, see page 32

Construction

Galvanized steel gates
Body: 14 gauge
Cover: 20 gauge
Blade: 3" - 8" are 14ga; 9" - 22" are 10ga

Optional End Types

Standard QF end can be changed to Raw ID (RI), Raw OD (RO), No Fitting (NF), Flat Flange (FLL), Angle Flange (AFL), or Van Stone (VS).

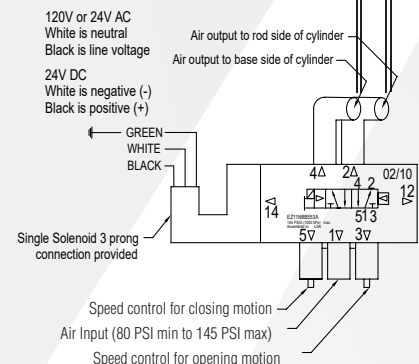
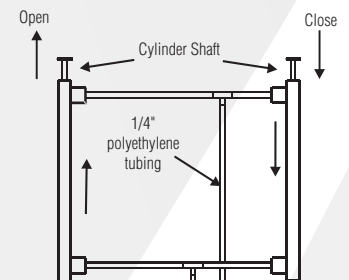

Additional Product Components and Notes				
Poly tube	0.25" OD x 0.04 wall poly tube, 120 PSI, Grade E5 LIP, Type 1			
Magnetic Cylinder	Gate Size	Stroke	No. of Cylinders	Bore
	3"	1.06 x 3.00	1	1.0625"
	4"	1.06 x 4.00		
	5"	1.06 x 5.00		
	6"	1.06 x 6.00		
	7"	1.06 x 7.00		
	8"	1.06 x 8.00		
	9"	1.06 x 9.00	2	
	10"	1.06 x 10.00		
	12"	1.06 x 12.00		
	14"	1.06 x 14.00		
	16"	1.06 x 16.00		
18"	1.06 x 18.00			
20"	1.06 x 20.00			
22"	1.06 x 22.00			
Crimped round body 304SS tube only. End caps aluminum (non-repairable).				
<ul style="list-style-type: none"> Ports 0.125" NPT standard Piston rod diameter 0.312", material 304SS only Single acting end Standard fluid: filtered air Operating medium: pneumatic, 250 PSI max. (normal operating pressure 80 PSI min.) 				
Solenoid Options	<ul style="list-style-type: none"> Single Solenoid, 2 Position, 110VAC, 2.5 watts, 1/8" NPT; IP65 Rated, RoHS, CE Single Solenoid, 2 Position, 24VDC, .25 watts, 1/8" NPT; IP65 Rated, RoHS, CE Single Solenoid, 2 Position, 24VAC, .25 watts, 1/8" NPT; IP65 Rated, RoHS, CE 			
Coil Options	<ul style="list-style-type: none"> 24VDC 24VAC / 12VDC 110VAC 			

SD Automatic Blast Gate

Ordering Information

- When ordering, specify gauge (if non-standard), dimension, end types and control circuit voltage. Material is Galvanized Steel.
- Operated by single acting compressed air magnetic cylinders, controlled by electrically connected solenoid.
- APPLICATION: Gates are used for industrial dust extraction where continuous extraction is not always needed and where manual control needs to be eliminated.

- Standard 120V control circuit and 75psi minimum air pressure. Optional 24V DC or AC control circuit available.
- All auto blast gates have cylinders with galvanized or SS body and steel rod. Single cylinder: 3" to 10". Double cylinder 12" to 24". Solenoid has plastic housing.

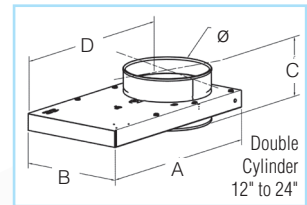
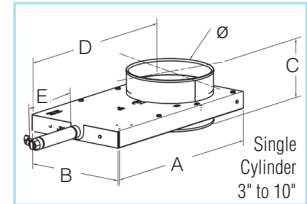

Ø in.	A in.	B in.	C in.	D in.	E in.	Std Weight Lbs
3	8.11	4.25	5.25	6.30	8.50	9.83
4	10.31	5.30	5.50	7.81	8.50	9.90
5	12.80	6.00	5.75	9.88	9.50	11.90
6	14.47	7.12	5.75	11.28	11.50	15.15
7	16.25	8.00	5.38	12.44	11.50	18.85
8	18.75	9.30	5.50	14.38	13.50	27.50
9	20.63	10.63	5.50	15.88	13.50	37.50
10	22.63	11.65	5.50	17.25	13.50	37.50
12	30.00	16.00	5.25	23.25	n/a	44.00
14	33.04	18.38	5.25	25.29	n/a	50.00
16	38.52	20.38	11.25	29.65	n/a	63.00
18	46.69	22.38	11.25	37.04	n/a	74.00
20	48.69	24.38	11.25	38.04	n/a	83.00
22	50.69	26.38	11.25	39.04	n/a	104.00
24	55.50	31.28	11.25	42.40	n/a	125.00

QF Material Options

Galv			
Gauges	Size (inches)		
	Min. Ø	Max. Ø	
Standard	22	3	12
	20	14	24
Optional	18 (Collar)	8	24
	16 (Collar)	8	24

Not available in SS

Flanged Material Options

Galv			
Gauges	Size (inches)		
	Min. Ø	Max. Ø	
Standard	22	3	12
	20	14	24
Optional	18 (Collar)	8	24
	16 (Collar)	8	24

Optional End Types

Standard QF end can be changed to Raw ID (RI), Raw OD (RO), No Fitting (NF), Flat Flange (FFL), Angle Flange (AFL), or Van Stone (VS).

Temperature Rating: Max. temperature limited to 120°F unless solenoids are located outside of housing. Max temperature for the Poly tubing on the outside of the housing and Seal (UHMW) is 150°F.

Additional Product Components and Notes

Poly tube	0.25" OD x 0.04 wall poly tube, 120 PSI, Grade E5 LIP, Type 1																																						
Magnetic Cylinder	<table border="1"> <thead> <tr> <th>Gate Size</th> <th>Stroke</th> <th>No. of Cylinders</th> <th>Bore</th> </tr> </thead> <tbody> <tr><td>3"</td><td>1.06 x 3.00</td><td rowspan="10">1</td><td rowspan="10">1.0625"</td></tr> <tr><td>4"</td><td>1.06 x 4.00</td></tr> <tr><td>5"</td><td>1.06 x 5.00</td></tr> <tr><td>6"</td><td>1.06 x 6.00</td></tr> <tr><td>7"</td><td>1.06 x 7.00</td></tr> <tr><td>8"</td><td>1.06 x 8.00</td></tr> <tr><td>9"</td><td>1.06 x 9.00</td></tr> <tr><td>10"</td><td>1.06 x 10.00</td></tr> <tr><td>12"</td><td>1.06 x 12.00</td><td rowspan="6">2</td><td rowspan="6">1.0625"</td></tr> <tr><td>14"</td><td>1.06 x 14.00</td></tr> <tr><td>16"</td><td>1.06 x 16.00</td></tr> <tr><td>18"</td><td>1.06 x 18.00</td></tr> <tr><td>20"</td><td>1.06 x 20.00</td></tr> <tr><td>22"</td><td>1.06 x 22.00</td></tr> <tr><td>24"</td><td>1.06 x 24.00</td></tr> </tbody> </table> <p>Crimped round body 304SS tube only. End caps aluminum (non-repairable).</p> <ul style="list-style-type: none"> • Ports 0.125" NPT standard • Piston rod diameter 0.312", material 304SS only • Single acting end • Standard fluid: filtered air • Operating medium: pneumatic, 250 PSI max. (normal operating pressure 80 PSI min.) 	Gate Size	Stroke	No. of Cylinders	Bore	3"	1.06 x 3.00	1	1.0625"	4"	1.06 x 4.00	5"	1.06 x 5.00	6"	1.06 x 6.00	7"	1.06 x 7.00	8"	1.06 x 8.00	9"	1.06 x 9.00	10"	1.06 x 10.00	12"	1.06 x 12.00	2	1.0625"	14"	1.06 x 14.00	16"	1.06 x 16.00	18"	1.06 x 18.00	20"	1.06 x 20.00	22"	1.06 x 22.00	24"	1.06 x 24.00
Gate Size	Stroke	No. of Cylinders	Bore																																				
3"	1.06 x 3.00	1	1.0625"																																				
4"	1.06 x 4.00																																						
5"	1.06 x 5.00																																						
6"	1.06 x 6.00																																						
7"	1.06 x 7.00																																						
8"	1.06 x 8.00																																						
9"	1.06 x 9.00																																						
10"	1.06 x 10.00																																						
12"	1.06 x 12.00			2	1.0625"																																		
14"	1.06 x 14.00																																						
16"	1.06 x 16.00																																						
18"	1.06 x 18.00																																						
20"	1.06 x 20.00																																						
22"	1.06 x 22.00																																						
24"	1.06 x 24.00																																						
Solenoid Options	<ul style="list-style-type: none"> • Single Solenoid, 2 Position, 110VAC, 2.5 watts, 1/8" NPT; IP65 Rated, RoHS, CE • Single Solenoid, 2 Position, 24VDC, .25 watts, 1/8" NPT; IP65 Rated, RoHS, CE • Single Solenoid, 2 Position, 24VAC, .25 watts, 1/8" NPT; IP65 Rated, RoHS, CE 																																						
Coil Options	<ul style="list-style-type: none"> • 24VDC • 24VAC / 12VDC • 110VAC 																																						

Reed Switch Assembly 1.06

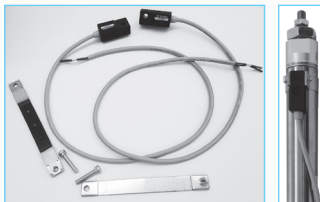

- **Optional** position (open/closed) D-B54 sensing switch with indicator light.
- Assembly includes two switches, one indicating open position and one indicating closed position.
- Applies to both types of Nordfab Automatic Blast Gates.

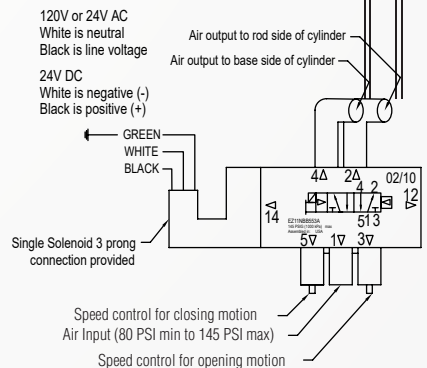
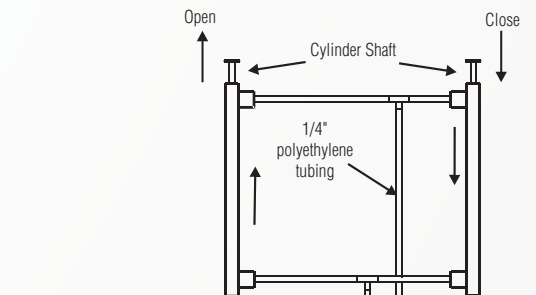

Rubber Hose, Black or Clear

Ordering Information

- When ordering, specify Black or Clear, dimension, and overall length. Supplied in 5' increments, ex. 5', 10', 15'.
- Black is thermoplastic flexible rubber hose reinforced with spring steel wire helix. 1" - 12" is sold in 5' increments up to 50' maximum. 14" - 24" sold in 5' increments up to 25' maximum.
- Clear is polyurethane flexible rubber hose reinforced with a bronze coated spring steel wire helix. 2" - 12" is sold in 5' increments up to 50' maximum. 14" - 16" sold in 5' increments up to 25' maximum.
- Order Hose or Bridge Clamps separately.
- The Hose Adapter can be used with this Hose.



Black Hose						
Inside Ø in.	Wall Thickness in.	CL Bend Radius in.	Compression Ratio in.	Negative Pressure in./hg	Working Pressure PSI	Approx Weight lbs/ft
1	N/A	N/A	N/A	N/A	N/A	.14
1.5	.025	1.7	2:1	29	25	.17
2		2	2:1	29	19	.24
2.5		2.5	2:1	29	14	.27
80mm		3	2:1	29	11	.34
4		4	2:1	29	10	.39
5		5.5	2:1	29	9	.50
5.5		6.5	2:1	17	8	.64
6		6.8	2:1	12.5	7	.71
7		6	3:1	11	7	.91
8		7	3:1	9	5	1.00
9	.030	8	3:1	5.5	4.5	1.04
10		9	3:1	10	4	1.20
12		10	3:1	6.5	4	1.60
14		12	3:1	5	3.8	2.00
16		14	3:1	3	3.2	2.40
18		16	3:1	2.3	2.6	2.80
20		18	3:1	2	2.3	3.60
22		21	3:1	1.5	2	4.00
24		25	3:1	.8	1.75	6.00



Temperature Rating: Black Hose: -65° to 275
Clear Hose: -65° to 225°

Technical data based on 2 ft. straight lengths of hose @ 72°

Clear Hose						
Inside Ø in.	Wall Thickness in.	CL Bend Radius in.	Compression Ratio in.	Negative Pressure in./hg	Working Pressure PSI	Approx Weight lbs/ft
2	.015	2.00	3:1	29.0	30.0	.25
2.5		2.75	4:1	19.0	30.0	.35
80mm		3.25	4:1	29.0	30.0	.40
4		3.75	4:1	24.0	22.0	.50
5		4.50	4:1	13.0	18.0	.60
6		5.25	4:1	8.0	15.0	.70
7	.020	5.88	5:1	8.0	10.0	.80
8		6.50	5:1	2.0	7.0	.90
9		N/A	5:1	N/A	N/A	N/A
10		7.50	5:1	2.0	7.0	1.20
12		9.00	5:1	1.7	6.0	1.40
14		12.00	5:1	1.1	5.0	1.60
16		14.00	5:1	7.0	4.6	1.80

Static Dissipative Urethane Hose, Clear

Ordering Information

- When ordering, specify size dimension, and overall length. Supplied in 5' increments, ex. 5', 10', 15'.
- Medium weight static dissipative polyurethane hose reinforced with a bronze coated spring steel wire helix.
- Great abrasion resistance & high tear strength as well as superior chemical resistance, excellent flexibility, and tolerance for applications with wide temperature ranges.
- Order Hose or Bridge Clamps separately.
- The Hose Adapter can be used with this Hose.



Inside Ø in.	Wall Thickness in.	CL Bend Radius in.	Compression Ratio in.	Negative Pressure in./hg	Working Pressure PSI	Approx Weight lbs/ft
3		3		29	29	.4
4		4		29	25	.7
5		5		17	22	.9
6		6		3:1	15	19
8	.030	8		9	14	1.5
10		8		4	11	1.6
12		10		2.2	10	2



Temperature Rating: -65° F to 225° F

Bridge Clamp for Hose

Ordering Information

- When ordering, specify dimension.
- Conforms to hose's wire helix for more secure fit.
- Stainless steel band and welded stainless steel bridge with carbon steel screw.
- Designed for use with clockwise wire helix hose.

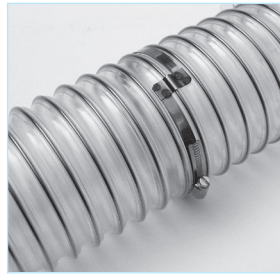

Ø in.	Weight lbs	Ø in.	Weight lbs
2	0.05	7	0.15
2.5	0.06	8	0.17
3	0.07	9	0.20
4	0.09	10	0.25
5	0.10	12	0.30

Hose Clamp

Ordering Information

- When ordering, specify dimension.
- 100% interlock construction features one piece housing which directly locks into the band of clockwise wound hose.
- Spot weld free design.
- 1/2" band and all other components are 16ga Stainless Steel. Slotted 5/16" hex head screw: 400 series stainless steel.
- Meets or exceeds SAE torque specifications.



Ø in.	Weight lbs	Ø in.	Weight lbs
2	0.05	12	0.20
3	0.06	14	0.25
4	0.07	16	0.30
5	0.08	18	0.40
6	0.09	20	0.45
7	0.10	22	0.50
8	0.14	24	0.60
9	0.15		
10	0.17		

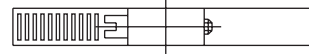

Flex Hose End Types

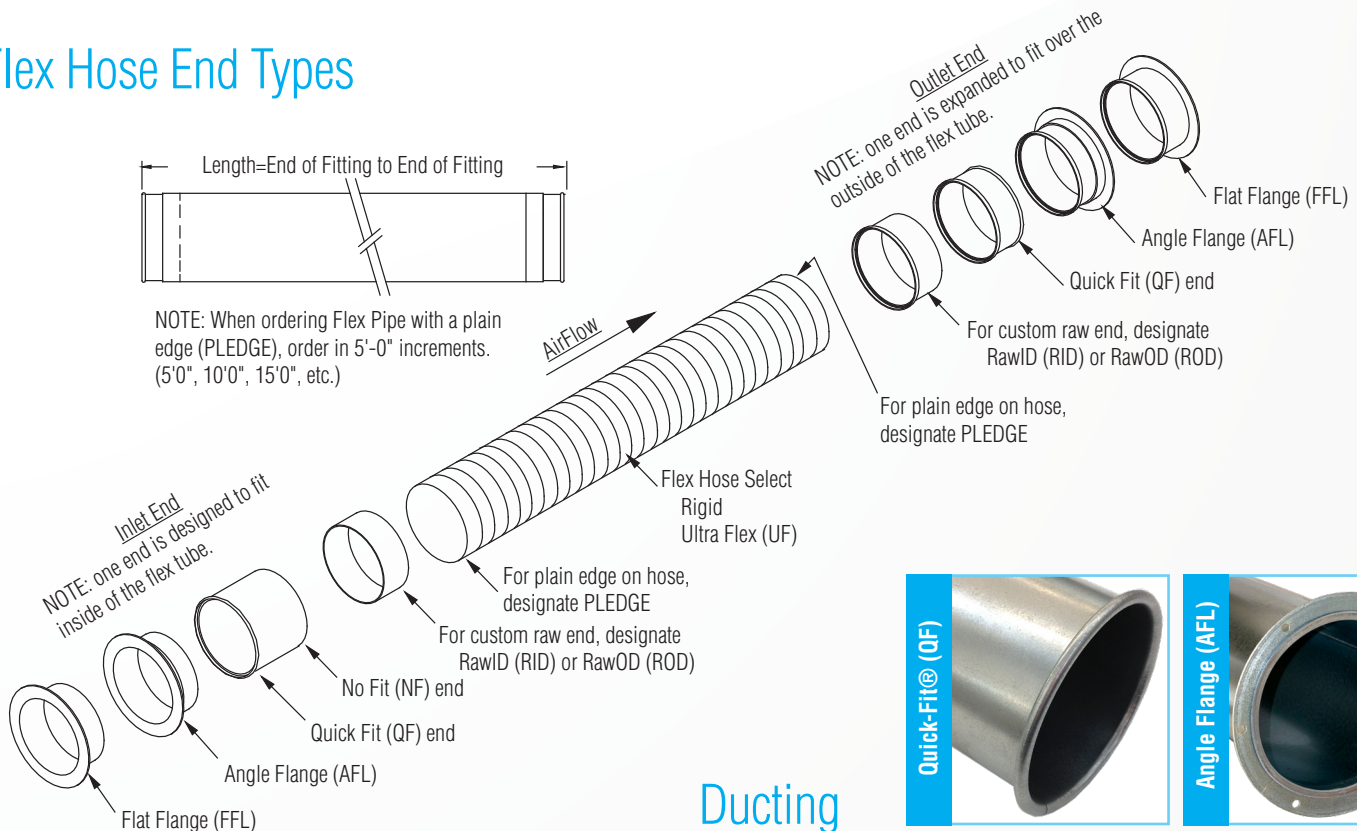

Ducting End Types

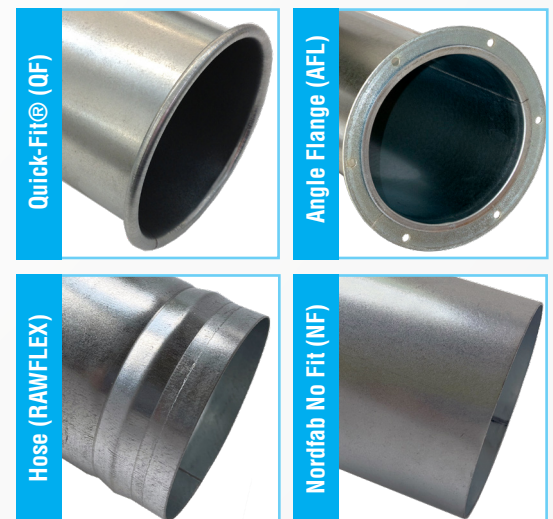

Rigid Flex Steel Hose ◊

Ordering Information

- When ordering, specify material (galvanized or Stainless Steel), size dimension, end type(s), and length. Supplied in 5' increments.
- Flexible rigid steel hose for higher temperature or abrasive material.
- 1.5" - 6" is sold in 5' increments up to a 25' maximum length. 7" - 14" hoses are sold in 5' increments only. If lengths longer than 5' are needed, Nordfab supplies 5' hose assemblies with Quick-Fit ends to easily connect additional assemblies.
- Raw ends standard when ordering steel hose. Assemblies with QF-QF and AFL-AFL ends are also available as standard. Other end types and combinations optional.



Optional End Types

Standard raw end can be changed to Raw ID, Raw OD, No fitting, Hose Adapter, Flat Flange, or QF (additional cost for hose assembly).

Size in.	ID in.	Approx. Outside Dia* in.	CL Bend Radius in.	Approx Weight per foot lbs
1.5	1.125	1.75	6.375	1.00
2	2.000	2.25	9.00	1.30
2.5	2.3125	2.75	10.25	1.60
3	3.0625	3.25	12.50	2.00
4	4.000	4.25	16.25	2.60
5	5.000	5.25	19.50	3.00
6	6.000	6.25	25.00	3.60
7	7.250	7.25	27.50	4.00
8	8.125	8.25	32.00	4.60
9	9.125	9.25	34.00	5.30
10	9.750	10.25	37.50	5.90
12	12.000	12.25	44.00	7.00
14	14.000	14.25	53.00	8.10

◊ Items may take longer than standard lead times.

Do **NOT** use standard SS Hose Clamps with these hoses.



Temperature Rating: Galvanized Steel max. 390° F / Stainless Steel max. 1500° F

*OD varies depending on how hose is wound

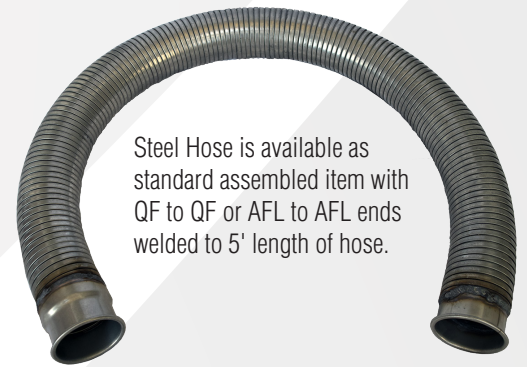

Steel Hose is available as standard assembled item with QF to QF or AFL to AFL ends welded to 5' length of hose.

Ultra Flex Steel Hose ◊

Ordering Information

- When ordering, specify material (galvanized or Stainless Steel), size dimension, end type(s), and length. Supplied in 5' increments.
- Flexible steel hose for higher temperature or abrasive material.
- 3" - 6" is sold in 5' increments up to a 25' maximum length. 7" - 8" hoses are sold in 5' increments only. If lengths longer than 5' are needed, Nordfab supplies 5' hose assemblies with Quick-Fit ends to easily connect additional assemblies.
- Raw ends standard when ordering steel hose. Assemblies with QF-QF and AFL-AFL ends are also available as standard. Other end types and combinations optional.



Optional End Types

Standard raw end can be changed to Raw ID, Raw OD, No fitting, Hose Adapter, Flat Flange, or QF (additional cost for hose assembly).

Size in.	ID in.	Approx. Outside Dia* in.	CL Bend Radius in.	Approx Weight per foot lbs
3	3.036	3.125	12	2.15
4	4.063	4.250	16	2.65
5	5.125	5.250	19	2.95
6	6.063	6.188	23	3.55
7	7.000	7.250	27	4.15
8	8.125	8.250	30	4.55

Do **NOT** use standard SS Hose Clamps with these hoses.



Temperature Rating: Galvanized Steel max. 390° F / Stainless Steel max. 1500° F

*OD varies depending on how hose is wound
Square lock: ID Tolerance +1/4", -0

◊ Items may take longer than standard lead times.

Barrel Hood

Ordering Information

- When ordering, specify material, size, and end type.
- Designed to fit 55 gallon drums.

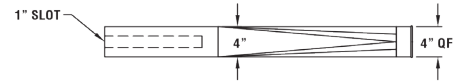
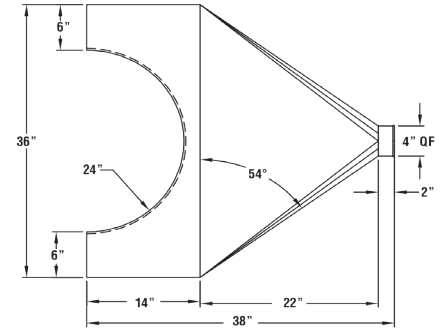
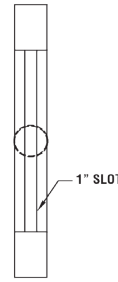
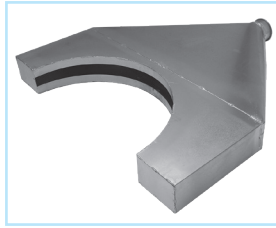

Construction:
Seams: lapped, spot welded, and caulked.

Optional End Types
 Standard QF end can be changed to Raw ID (RI), Raw OD (RO), No Fitting (NF), Flat Flange (FFL), Angle Flange (AFL), or Van Stone (VS).

Ø in.	Std Weight Lbs
4	14.5
6	14.5
8	14.5

QF Material Options

Galv				SS			
Gauges	Size (in)		Gauges	Size (in)			
	Min. Ø	Max. Ø		Min. Ø	Max. Ø		
Std	18	4	8	Std	18	8	8

Flanged Material Options

Galv				SS			
Gauges	Size (in)		Gauges	Size (in)			
	Min. Ø	Max. Ø		Min. Ø	Max. Ø		
Std	18	4	8	Std	18	8	8

Bell Mouth Hood

Ordering Information

- When ordering, specify material, collar gauge (if non-standard), size, and end type. The bell begins as 18 gauge and thickness cannot be changed.
- Flared end hood increases capture ratio of air, dust, smoke, etc.
- Increases laminar air flow.



Ø in.	Bell OD in.	Height in.	Flat Rim in.	Std Weight Lbs
3	8.0	4.5*	1.00*	.90
4	9.0	4.5*	1.00*	1.05
5	10.0	4.5*	1.00*	1.15
6	12.0	5.0*	1.25*	1.85
7	13.0	5.0*	1.25*	1.95
8	14.0	5.0*	1.25*	2.10
9	15.0	5.0*	1.25*	2.25
10	16.0	6.0*	1.25*	3.00
11	19.0	6.0*	1.25*	3.70
12	20.0	6.0*	1.25*	4.10
13	21.0	6.0*	1.25*	4.50
14	22.0	6.0*	1.25*	5.75
15	23.0	6.0*	1.5*	6.25
16	26.0	7.0*	1.5*	7.50
17	27.0	7.0*	1.5*	8.25
18	28.0	7.0*	1.5*	9.50
19	29.0	7.0*	1.5*	10.10
20	30.0	7.0*	1.5*	10.75
21	31.0	8.0*	1.75*	11.50
22	34.0	8.0*	1.75*	12.25
23	35.0	8.0*	1.75*	12.90
24	36.0	8.0*	1.75*	14.50

Galv				SS			
Gauges (Collar)	Size (in)		Gauges (Collar)	Size (in)			
	Min. Ø	Max. Ø		Min. Ø	Max. Ø		
Std	22	3	12	Std	22	3	12
	20	13	24		20	13	24

◇ SS Bell Mouth Hoods have a lead time of 4-5 business days minimum.

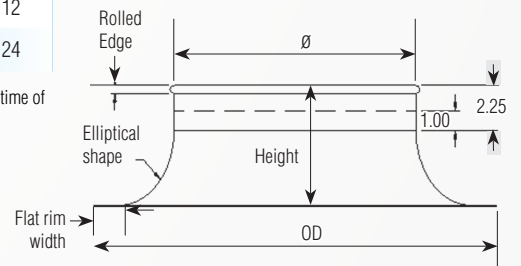

Construction:

Bell: constructed from a solid sheet so no seams are present in the bell portion. Bell begins as 18ga; thickness cannot be changed.

Collars: have a laser welded longitudinal seam. Collars are attached to the body using a raised hemmed, spot welded seam construction.

Optional End Types

Standard QF end can be changed to Raw ID (RI), Raw OD (RO), No Fitting (NF), Flat Flange (FFL), Angle Flange (AFL), or Van Stone (VS).

Canopy Hood

Ordering Information

- When ordering, specify material, gauge (if non-standard) and opening size. 18" square, 24" square, 36" square, or 48" square. Other sizes available upon request. Maximum size 72"x48".
- Hemmed end standard.
- If flange needed, please see Transitions.

Ø in.	H in.	W in.	X in.	Y in.	L in.	Std Weight Lbs
16	18	18	4	2	15.5	9.00
16	24	24			20	16.00
18	36	36			29	36.00
18	48	48			38	64.00

Construction:

Seam: lapped, spot welded, and caulked.

Collars: located on the exterior side of each port and considered as air flow non-directional. Collars have a laser welded longitudinal seam. If air flow directional product is required, it must be stated on the PO and additional cost may be incurred. A raised lap seam and spot weld are used for attaching the collar to the body and no caulking is used. If caulking is required, additional cost may be incurred.

Optional End Types (Round End)

Standard QF end can be changed to Raw ID (RI), Raw OD (RO), No Fitting (NF), Flat Flange (FLL), Angle Flange (AFL), or Van Stone (VS).

Square End: Hemmed edge.

QF Material Options

Galv				SS			
Gauges	Size (in)		Gauges	Size (in)			
	Min. Ø	Max. Ø		Min. Ø	Max. Ø		
Std	20	16 (18" H & W)	Std	20	16 (18" H & W)		
	18	16 (24" H & W)		18	16 (24" H & W)		
	16	18 (36" H & W)		16	18 (36" H & W)		
	14	18 (48" H & W)		14	18* (48" H & W)		
Optional	18	16	Optional	18	16		
	16	16		16	16		
	14	16		16	16		

* 16ga collar

*NOTE: Minimum L = .75 (W). If less, square to square transition will be provided. 7" minimum L allowable for Sq to Rd and 4" L minimum allowable for Sq to Sq.

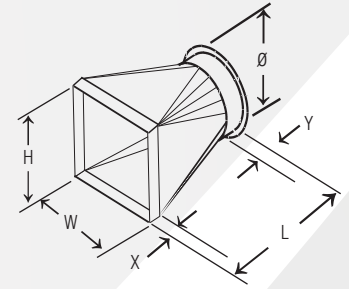
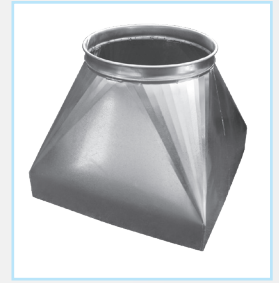

Hood Design Basis:
150 fpm capture velocity
2 ft. distance from source

Radial Arm Saw Hood

Ordering Information

- When ordering, specify material and size.
- Used to collect dust from Radial Arm Saws.
- Body is 18 gauge. Collar and transition are 22 gauge as standard construction.



QF Material Options

Ø in.	L in.	Std Weight Lbs
4	15.5	3.50
5	20	3.90
6	29	4.20

Galv				SS			
Gauges	Size (in)		Gauges	Size (in)			
	Min. Ø	Max. Ø		Min. Ø	Max. Ø		
Standard	Collar*	4	Standard	Collar*	4		
	22	6		22	6		
Body is 18ga			Body is 18ga				

Flanged Material Options

Galv				SS			
Gauges	Size (in)		Gauges	Size (in)			
	Min. Ø	Max. Ø		Min. Ø	Max. Ø		
Standard	Collar*	4	Standard	Collar*	4		
	22	6		22	6		
Body is 18ga			Body is 18ga				

* Collar and transition. Contact Nordfab if you have need of additional collar gauge options.

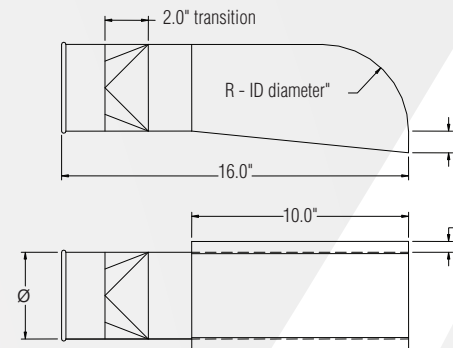

Construction:

Seam: spot welded and caulked.

Collars: have a laser welded longitudinal seam. Collars are attached to the body using a raised hemmed, spot welded seamed construction and are painted at welds.

Optional End Types

Standard QF end can be changed to Raw ID (RI), Raw OD (RO), No Fitting (NF), Flat Flange (FLL), Angle Flange (AFL), or Van Stone (VS).

Router Hood | Router Hood with Magnets

Ordering Information

- When ordering, specify material and size. Order magnets if needed.
- Standard rectangular opening is 6"x12".
- Magnet is not available in SS.
- If ordered, two magnets are mounted on each hood.

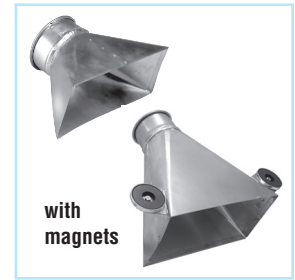

with magnets

Ø in.	Std Weight lbs	With Magnets Std Weight lbs
3	2.40	3.40
4	2.85	4.60
5	3.00	5.50
6	3.20	6.40
7	3.50	7.25
8	4.00	8.50
9	6.20	12.40
10	8.50	17.00

QF Material Options

Galv				SS			
Gauges	Size (in)		Gauges	Size (in)			
	Min. Ø	Max. Ø		Min. Ø	Max. Ø		
Std	22	3	10	Std	22	3	10

Magnet is not available in SS.

Flanged Material Options

Galv				SS			
Gauges	Size (in)		Gauges	Size (in)			
	Min. Ø	Max. Ø		Min. Ø	Max. Ø		
Std	22	3	10	Std	22	3	10

Construction:

Seam: lapped, spot welded, and caulked.

Collars: located on the exterior side of each port and considered as air flow non-directional. Collars have a laser welded longitudinal seam. If air flow directional product is required, it must be stated on the PO and additional cost may be incurred. A raised lap seam and spot weld are used for attaching the collar to the body and no caulking is used. If caulking is required, additional cost may be incurred.

Optional End Types (Round End)

Standard QF end can be changed to Raw ID (RI), Raw OD (RO), No Fitting (NF), Flat Flange (FFL), Angle Flange (AFL), or Van Stone (VS).

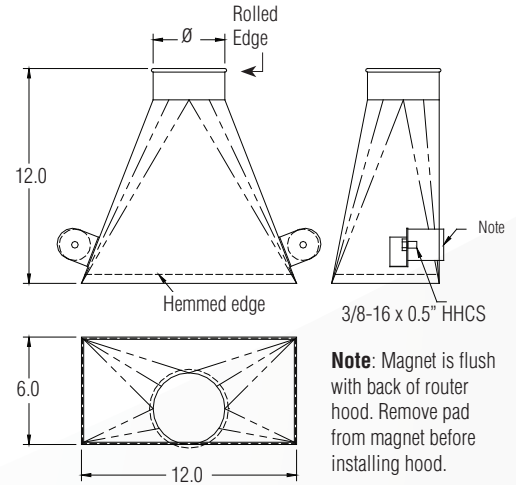

Temperature Rating: Max. temperature limited to 300°F if magnets used, due to physical characteristics of the magnets' Ferrite construction.

Suction Hood

Ordering Information

- When ordering, specify material, gauge (if non-standard), size, dimensions for each pickup (hood can be constructed with any number of pickups from 2 to 6), and either Round or Rectangular openings.

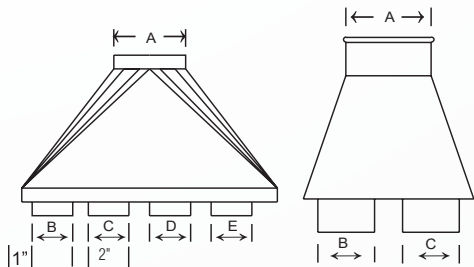

Construction:

Seam: spot welded and caulked.

Collars: have a laser welded longitudinal seam. Collars are attached to the body using a raised hemmed, spot welded seamed construction.

Optional End Types

Standard QF end can be changed to Raw ID (RI), Raw OD (RO), No Fitting (NF), Flat Flange (FFL), Angle Flange (AFL), or Van Stone (VS).

Custom Manifolds

Ordering Information

- Use this form to order custom manifolds.

From: _____ Date: _____

Tel: _____ Email _____

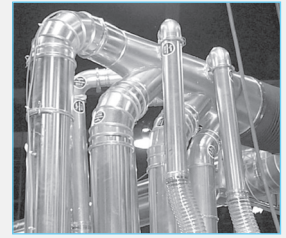

Provide the following information when ordering a dust collection manifold.

- 1 Connecting Diameter? _____
- 2 Floor to Centerline Height? _____
- 3 Machine Height? _____
- 4 Location of Main Line? _____ OUTFEED? INFEED? (select one)
- 5 Number of connections? _____ HARD PIPE? FLEX? (select one)
- 6 Provide a port layout, including connection diameters.

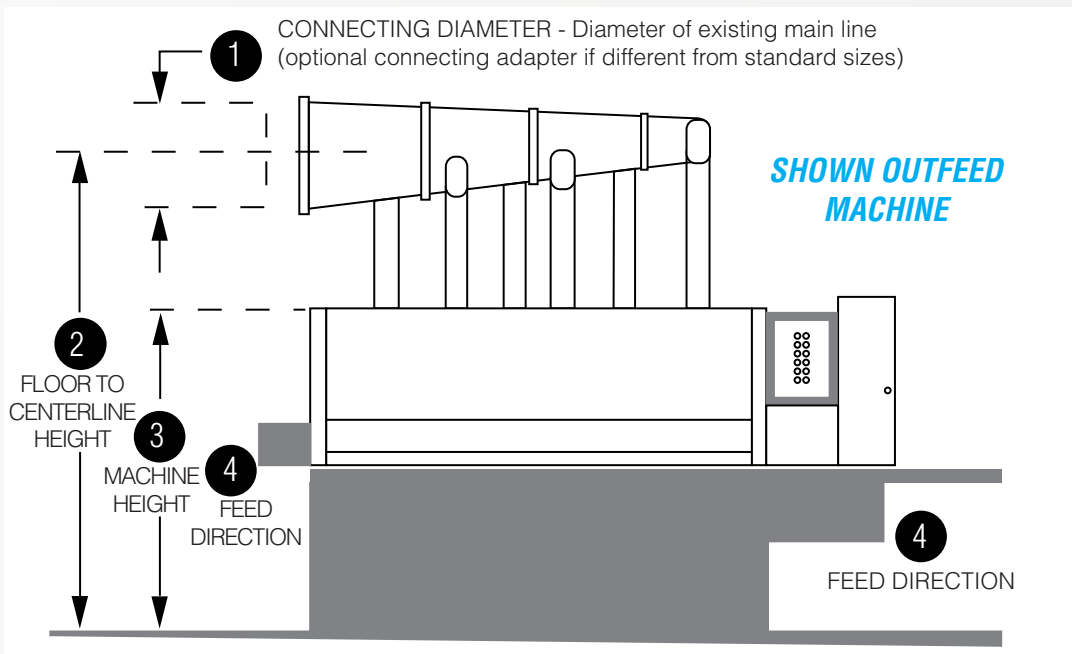
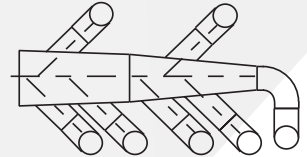

Nordfab Drawing Service

Provide Nordfab with basic information about the job:

- Material conveyed
- Machine type and placement
- Recommended velocity

Nordfab will provide you with an AutoCAD, QFV®, or PDF file of the drawing, complete with a list of the Nordfab parts set forth in the drawing, and a quote.

Drawing service costs will be refunded when a related order is submitted. Include the part number DS/MC-CP for credit, referenced to the purchased drawing service order number.

FREE with Order

Diverter Valve - Manual or Automatic

Ordering Information

- When ordering, specify material (Mild Steel or SS), gauge (if non-standard), dimension, end types, choice of Manual or Automatic Open / Close and, if Automatic, control circuit voltage.
- High efficiency, economical method of diverting flow of material or air.
- Housing is heavy duty construction of painted 3/16" thick mild steel with welded seams. Heavy duty flange bearings and rubber seal in 14ga steel door. Rubber seal is 1/4" thick polymer compound #AB-3205.
- Auto: Standard 120V control circuit and 75psi minimum air pressure. Optional 24V DC control circuit available.
- Auto Diverter Valves have single magnetic cylinders with galvanized or SS body and steel rod. Solenoid has plastic housing.
- 45° only.



Ø in.	A in.	B in.	Length in.	Manual Std Weight lbs	Auto Std Weight lbs
3	6	14	26	15.00	22.50
4	6	14	26	20.00	27.00
5	6	15.25	27.25	30.00	37.50
6	6	16	28	44.00	51.00
7	6	16	28	60.00	67.50
8	6	17	29	66.50	74.00
9	8	18	34	85.40	92.90
10	8	20	36	100.00	107.50
11	8	20	36	115.00	140.00
12	8	24	40	130.00	154.00
13	8	24	40	146.50	177.50
14	8	28	44	170.00	198.50
15	8	28	44	190.00	227.40
16	8	32	48	220.00	260.00
17	8	32	48	337.00	345.00
18	8	36	52	392.00	400.00
20	10	40	60	447.00	455.00
22	10	41.25	61.25	522.50	530.00
24	10	48	68	625.10	635.00

Other sizes available upon request.

QF Material Options

Galv (Collar)				SS		
Gauges	Size (inches)		Gauges	Size (inches)		
	Min. Ø	Max. Ø		Min. Ø	Max. Ø	
Standard	22	3	Standard	22	3	
	20	13		20	13	
Optional	18	4	Optional	18	8	
	16	8		16	8	
	14	8		24	24	

Flanged Material Options

Galv (Collar)				SS		
Gauges	Size (inches)		Gauges	Size (inches)		
	Min. Ø	Max. Ø		Min. Ø	Max. Ø	
Standard	22	3	Standard	22	3	
	20	13		20	13	
Optional	18	4	Optional	18	8	
	16	8		16	8	
	14	8		24	24	
	12	10				

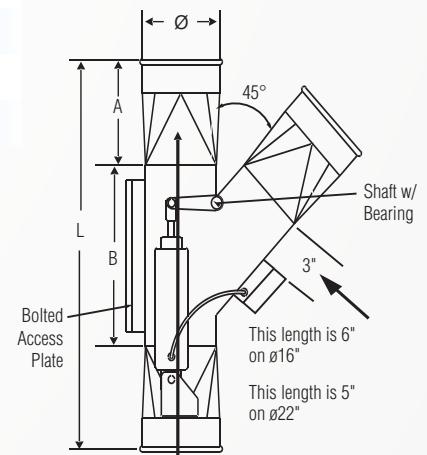
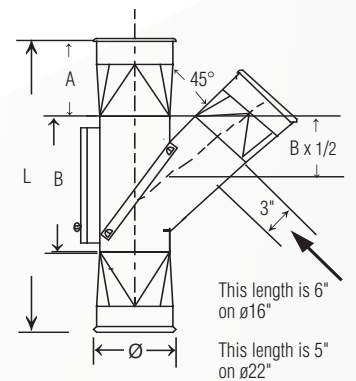

Additional Product Components and Notes				
Poly tube	0.25" OD x 0.04 wall poly tube, 120 PSI, Grade E5 LIP, Type 1			
Roller Bearing	Valve Size	Mfr. Part No. (Powerite)		
	4" - 6"	UCFL 204-12		
	7" - 16"	UCFL 205-16		
	18" - 24"	UCFL 206-20		
Magnetic Cylinder	Valve Size	Stroke	No. of Cylinders	Bore
	3" - 8"	2.25 x 4.00	1	2.5"
	9" - 12"	2.25 x 6.00		
	13" - 16"	2.25 x 8.00		
	17" - 24"	2.25 x 10.00		
Double Solenoid Options	<ul style="list-style-type: none"> • 2 position, 110VAC, 2.5 watts, 1/8" NPT, IP65 Rated • 2 position, 24VDC, .35 watts, 1/8" NPT, IP65 Rated 			
Coil Options	<ul style="list-style-type: none"> • 24VDC • 12VDC • 240VAX • 110VAC 			

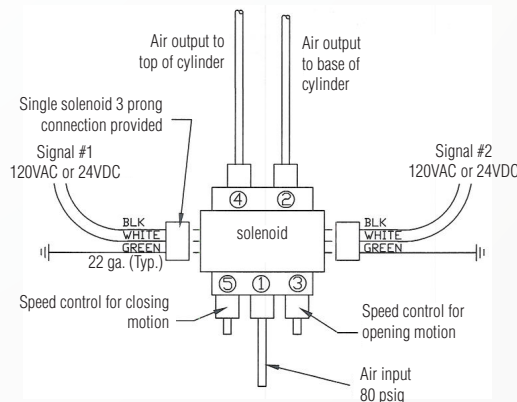

◇ Diverter Valves have a lead time of **7 days** minimum

SD Diverter Valve - Manual or Automatic

Ordering Information

- When ordering, specify material, gauge (if non-standard), dimension, end types, choice of Manual or Automatic Open / Close and, if Automatic, control circuit voltage.
- High efficiency, economical method of diverting flow of material or air.
- Standard unit is heavy duty construction of 14ga galvanized steel or SS with bolted seams. Heavy duty flange bearings and rubber seal in 14ga steel door. Rubber seal is 1/4" thick polymer compound #AB-3205.
- Auto: Standard 120V control circuit and 75psi minimum air pressure. Optional 24V DC control circuit available.
- SD Auto Diverter Valves have single magnetic cylinders with galvanized or SS body and steel rod. Solenoid has plastic housing.
- 45° angle only.
- Reverse flow available upon request.



Ø in.	A in.	B in.	Length in.	Manual Std Weight lbs	Auto Std Weight lbs
3	6	15	27	10.00	15.00
4	6	15	27	10.00	15.00
5	6	15	27	10.00	15.00
6	6	14	26	22.00	27.00
7	6	14	26	22.00	27.00
8	6	16	28	37.00	42.00
9	8	16	32	37.00	42.00
10	8	19	35	55.00	60.00
11	8	19	35	55.00	60.00
12	8	23	39	73.00	78.00
13	8	23	39	73.00	78.00

QF Material Options

Galv				SS			
Gauge	Size (in)		Gauge	Size (in)			
	Min. Ø	Max. Ø		Min. Ø	Max. Ø		
Standard	Body* 14	3	13	Standard	Body* 14	3	13

Flanged Material Options

Galv				SS			
Gauge	Size (in)		Gauge	Size (in)			
	Min. Ø	Max. Ø		Min. Ø	Max. Ø		
Standard	Body* 14	3	13	Standard	Body* 14	3	13

* Collar - see gauge chart on Diverter Valves, previous page

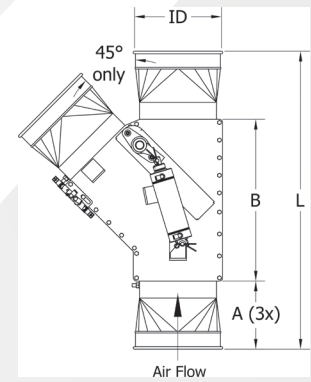
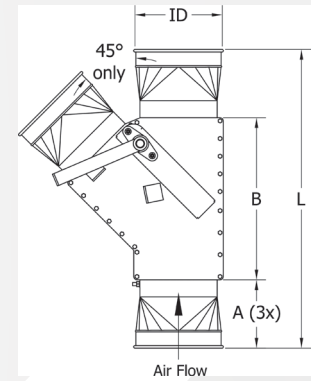

Additional Product Components and Notes				
Poly tube	0.25" OD x 0.04 wall poly tube, 120 PSI, Grade E5 LIP, Type 1			
Roller Bearing	Valve Size	Mfr. Part No. (Powerite)		
	4" - 6"	UCFL 204-12		
Magnetic Cylinder	Valve Size	Stroke	No. of Cylinders	Bore
	3" - 8"	2.25 x 4.00	1	2.5"
Double Solenoid Options	0.8Cv flow characteristics constant pressure			
	• 2 position, 110VAC, .35 watts, 1/8" NPT, IP65 Rated • 2 position, 24VDC, .86 watts, 1/8" NPT, IP65 Rated			
Coil Options	<ul style="list-style-type: none"> • 24VDC • 12VDC • 240VAX • 110VAC 			

Temperature Rating: Max. temperature limited to 212°F due to rating for Polymer SBR/CR tubing.

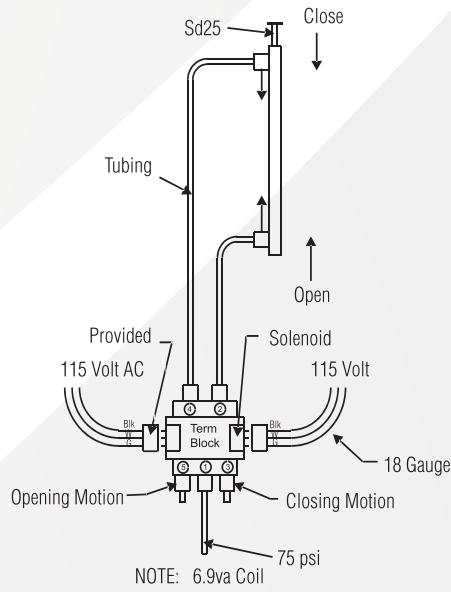

Reed Switch Assembly 2.50

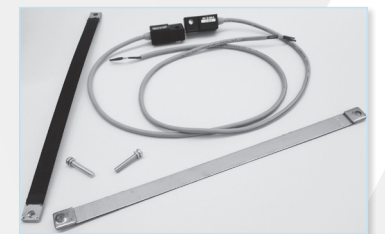

- Optional position (open/closed) D-B54 sensing switch with indicator light.
- Assembly includes two switches, one indicating open position and one indicating closed position.
- Applies to both types of automatic Diverter Valves.



◇ Diverter Valves have a lead time of **7 days** minimum

Gripple Hanger

Ordering Information

- Specify size. Length is 15 feet.
- Most common hanging method for QF duct due to ease of use.

Size by Weight

Up to 22lbs

Up to 100lbs

Up to 200lbs

Up to 495lbs

Up to 715lbs



Strut Hanger

Ordering Information

- Tested by MET Laboratories to hold up to 170lbs for 9" and up to 850lbs for 20" without failure.
- For strut channel mounting (strut not included).
- Nut and bolt included.



Galv			SS		
Gauges	Size (in)		Gauges	Size (in)	
	Min. Ø	Max. Ø		Min. Ø	Max. Ø
Std 14	3	24	Std 16	3	24

Ø in.	Std Weight Lbs
3	0.40
4	0.45
5	0.50
6	0.60
7	0.65
8	0.75
9	0.85
10	.95
11	1.00
12	1.10
13	1.20
14	1.15
15	1.30
16	1.35
17	1.40
18	1.50
20	1.80
22	4.10
24	5.00

Pipe Hanger

Ordering Information

- Specify size and material.
- Supplied with two halves bolted together.

Ø in.	Weight Lbs	Galv or Carbon Steel			SS				
		Gauges	Size (in)		Gauges	Size (in)			
Min. Ø	Max. Ø		Min. Ø	Max. Ø					
3	0.40	Standard	14ga Galv Steel	3	24	Std	16	3	40
4	0.45								
5	0.50								
6	0.60		7ga Carbon Steel	26	40				
7	0.65								
8	0.75								
9	0.85								
10	.95								
11	1.00								
12	1.10								
13	1.20								
14	1.25								
15	1.30								
16	1.35								
17	1.40								
18	1.50								
20	1.80								
22	4.10								
24	5.00								
26	6.10								
28	6.50								
30	6.90								
32	7.30								
34	7.70								
36	8.10								
38	8.50								
40	8.90								

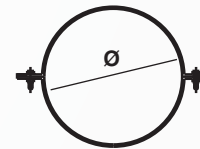

Pipe Hanger HJ

Ordering Information

- Specify size and material.
- Clearance hole 7/16".
- Supplied with two halves bolted together.



Ø in.	Weight Lbs	Galv			SS				
		Size (in)		Gauges	Size (in)		Gauges		
Min. Ø	Max. Ø	Min. Ø	Max. Ø						
3	0.45	Std	14	3	24	Std	16	3	24
4	0.55								
5	0.65								
6	0.75								
7	0.85								
8	0.95								
9	1.05								
10	1.15								
11	1.30								
12	1.45								
13	1.60								
14	1.75								
15	1.90								
16	2.20								
17	2.50								
18	2.85								
20	3.40								
22	4.10								
24	5.00								

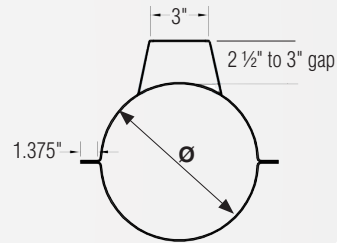
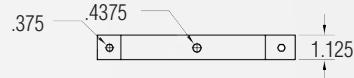

Clamp Hanger

Ordering Information

- Specify size and material.
- Cannot be used as a Clamp connection.
- Clearance hole 7/16".

Ø in.	Weight Lbs	Galv			SS				
		Size (in)		Gauges	Size (in)		Gauges		
Min. Ø	Max. Ø	Min. Ø	Max. Ø						
3	0.45	Std	14	3	24	Std	16	3	24
4	0.55								
5	0.65								
6	0.75								
7	0.85								
8	0.95								
9	1.05								
10	1.15								
11	1.30								
12	1.45								
13	1.60								
14	1.75								
15	1.90								
16	2.20								
17	2.50								
18	2.85								
20	3.40								
22	4.10								
24	5.00								

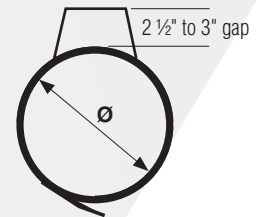

QF Wall Flashing

Ordering Information

- When ordering, specify material and size.
- Provides cover for wall penetration.
- Ordering one Flashing provides you with both one inside and one outside flashing (4 halves).
- Flashing can be ordered with Raw collar with or without lip.

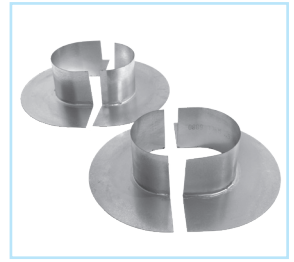

Ø in.	Weight Lbs
4	0.62
5	0.84
6	1.12
7	1.35
8	1.63
9	1.94
10	2.26
11	2.47
12	2.97
13	3.30
14	4.41
15	5.10
16	5.60
17	6.10
18	6.74
19	7.25
20	7.68
21	8.13
22	8.94
23	9.20
24	11.25

Material Options

Galv				SS			
Gauges	Size (in)		Gauges	Size (in)			
	Min. Ø	Max. Ø		Min. Ø	Max. Ø		
20	4	24	20	4	24		

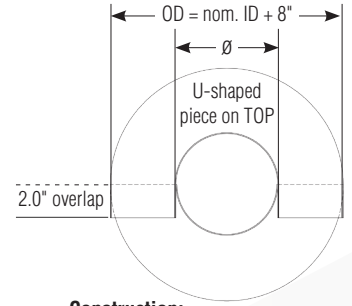
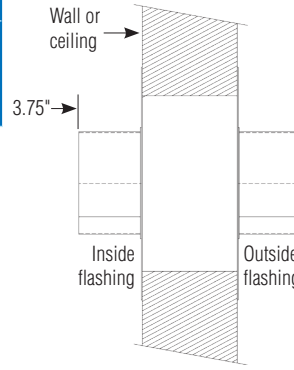

Construction:
Seam: Spot welded and caulked.

QF Roof Flashing

Ordering Information

- When ordering, specify material and size.
- Provides cover for roof penetration.
- Made in two halves and caulked.
- 23° roof slope maximum.



Ø in.	Weight Lbs
4	0.62
5	0.84
6	1.12
7	1.35
8	1.63
9	1.94
10	2.26
11	2.47
12	2.97
13	3.30
14	4.41
15	5.10
16	5.60
17	6.10
18	6.74
19	7.25
20	7.68
21	8.13
22	8.94
23	9.20
24	11.25

Material Options

Galv				SS			
Gauges	Size (in)		Gauges	Size (in)			
	Min. Ø	Max. Ø		Min. Ø	Max. Ø		
20	4	24	20	4	24		

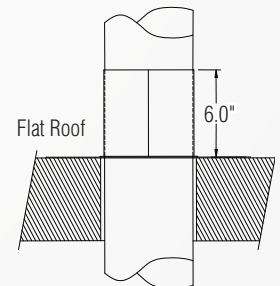
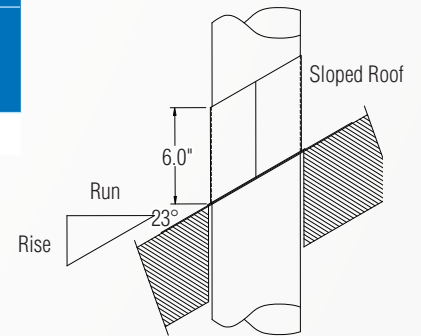
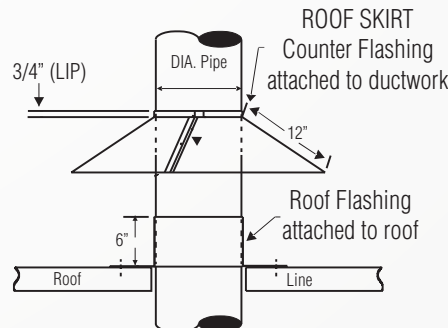
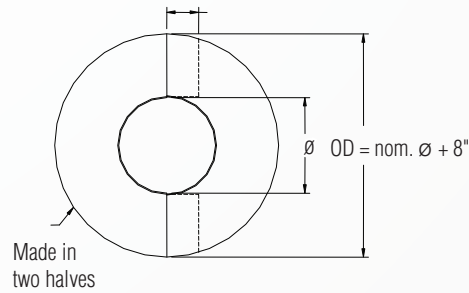

Construction:
Seam: Spot welded and caulked.

QF Roof Skirt

Ordering Information

- When ordering, specify material and size.
- Provides weather protection for roof penetration.
- Bolted at seam.
- 23° slope maximum.



Ø in.	Weight Lbs
4	0.62
5	0.84
6	1.12
7	1.35
8	1.63
9	1.94
10	2.26
11	2.47
12	2.97
13	3.30
14	4.41
15	5.10
16	5.60
17	6.10
18	6.74
19	7.25
20	7.68
21	8.13
22	8.94
23	9.20
24	11.25

Material Options

Galv				SS			
Gauges	Size (in)		Gauges	Size (in)			
	Min. Ø	Max. Ø		Min. Ø	Max. Ø		
Std 20	4	24	Std 20	4	24		

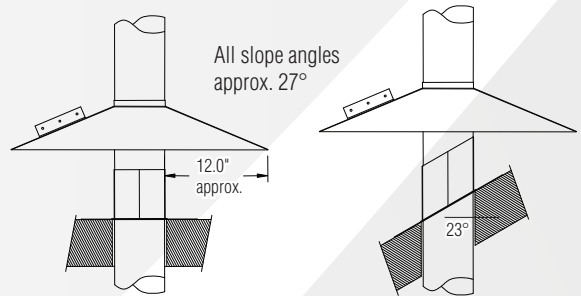
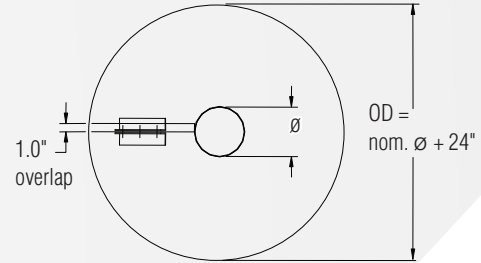

QF Weather Cap

Ordering Information

- When ordering, specify material and size.
- Provides weather protection for roof penetration. The wide cap minimizes risk of precipitation entering dust collection system and the screen reduces risk of the entry of unwanted wildlife and debris. The addition of the inner cone helps to reduce backpressure and improve system performance.



Ø in.	Width in.	Height in.	Std Weight Lbs
3	6	10.5	1.6
4	8	10.7	2.3
5	10	12.3	3.2
6	12	14.0	4.2
7	14	15.7	5.8
8	16	17.3	7.1
9	18	19.0	8.5
10	20	20.7	10.1
12	24	24.0	13.7
14	28	28.8	17.7
16	32	32.2	22.4
18	36	35.5	29.8
20	40	38.8	35.7
22	44	42.2	42.1
24	48	45.5	49.1

Material Options

Galv				SS			
Gauges	Size (in)		Gauges	Size (in)			
	Min. Ø	Max. Ø		Min. Ø	Max. Ø		
Std	22	3	3	Std	22	3	3
	18	4	24		18	8	24

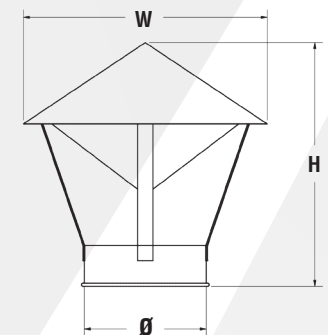

No-Loss Stackhead

Ordering Information

- When ordering, specify material, gauge (if non-standard), dimension and end type.
- Used when exhausting from fans or stacks through roof
- Eliminates back pressure on fan while providing weather protection.
- Flange is for guide wire attachment.
- Air flow directional arrow sticker is attached to product.



\varnothing in.	Angle Flange \varnothing in.	B in.	Std Weight Lbs
3	4	18	4.00
4	5	22	6.50
5	6	26	8.00
6	7	30	10.00
7	8	34	14.00
8	9	38	23.08
9	10	42	32.00
10	11	46	36.00
11	12	50	39.00
12	13	54	42.00
13	14	58	45.00
14	15	62	50.00
15	16	66	56.00
16	17	70	60.00
17	18	74	64.00
18	19	78	69.75
20	21	86	79.16
22	23	94	84.00
24	25	102	98.56
26	27	110	118.00
28	29	118	132.05
30	31	126	143.90
32	33	134	152.83
34	35	142	160.76
36	37	150	170.81
38	39	158	179.81
40	41	166	193.25

QF Material Options (Bottom Inner Pipe)

Galv				SS			
Gauges	Size (in)		Gauges	Size (in)			
	Min. \varnothing	Max. \varnothing		Min. \varnothing	Max. \varnothing		
Standard	22	3	12	22	3	12	
	20	13	24	20	13	24	
Optional	18	4	24	Optional	16	8	24
	16	8	24				
	14	8	24				

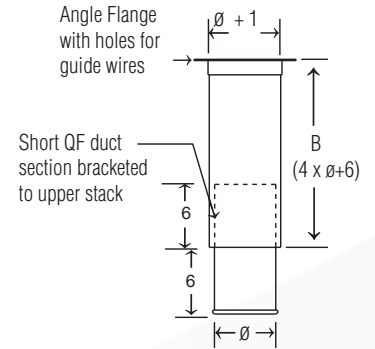

Flanged Material Options (Bottom Inner Pipe)

Galv (Std)				SS			
Gauges	Size (inches)		Gauges	Size (inches)			
	Min. \varnothing	Max. \varnothing		Min. \varnothing	Max. \varnothing		
Standard	22	3	12	22	3	12	
	20	13	28	20	13	28	
	18	30	40	18	30	40	
Optional	18	4	28	Optional	18	8	28
	16	8	40		16	8	40
	14	8	50				
	12	10	72				

Jet Cap

Ordering Information

- When ordering, specify material, dimension and end type.
- Prevents rain from entering ducting. Inner funnel allows rain to drain from ductwork even when system not running.
- Has three angle brackets for guide wire attachment.
- Installs in seconds with standard QF Clamp.



Ø in.	Width in.	Height in.	Std Weight Lbs	Material Gauges Galvanized and 304SS QF and Flanged		
				Upper	Lower	Collar
6	10.12	14.69	14.00	22	22	22
8	13.25	18.69	33.00	22	22	22
10	16.50	22.69	51.00	22	22	22
12	20.00	27.15	59.00	22	16	22
13	21.50	30.19	63.00	20	16	20
14	23.12	32.86	70.00	20	16	20
15	24.50	34.19	79.00	20	16	20
16	26.50	36.48	84.00	20	16	20
17	27.70	37.99	90.00	20	16	20
18	29.50	39.99	98.00	20	16	20
20	32.50	44.29	111.00	18	16	20
22	35.40	47.69	118.00	16	16	20
24	41.00	55.94	187.00	16	14	14
26	46.00	60.44	219.00	16	14	14
28	49.00	64.59	242.00	16	14	14
30	52.00	68.34	264.00	16	12	12
32	55.00	72.60	279.00	16	12	12
34	58.00	76.59	296.00	16	12	12
36	62.00	81.59	314.00	16	12	12
38	65.00	85.59	330.00	16	12	12
40	68.00	88.89	353.00	16	12	12

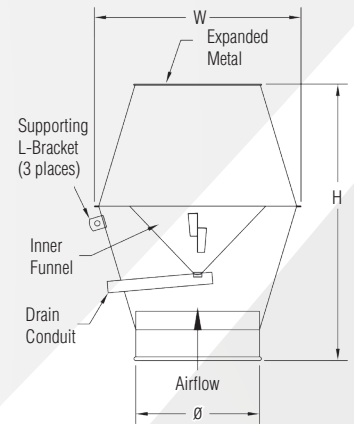
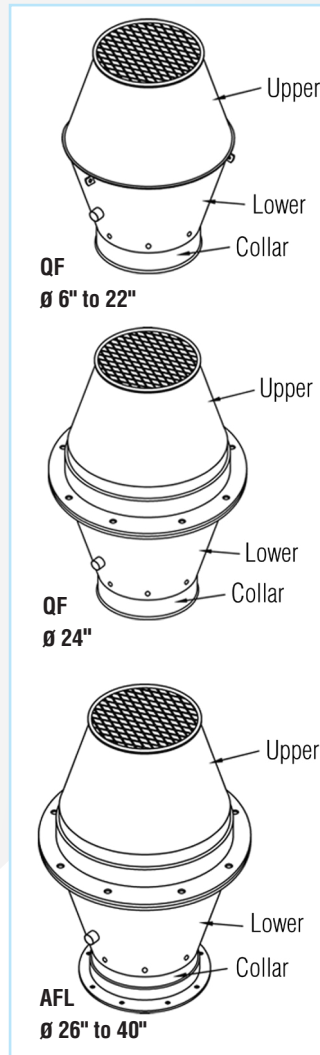

Construction
Top screen: expanded metal, 3/4" diamond pattern Koga painted mild steel.
Collars: Collars have a laser welded longitudinal seam.
Drain conduit:
 3/4" dia. used for 6" - 14" diameters
 1-1/2" dia. used for 15" - 24" diameters
 2" dia. used for 26" and larger diameters
Optional End Types: Standard QF end can be changed to Raw ID (RI), Raw OD (RO), No Fitting (NF), Hose Adapter (RF), Flat Flange (FFL), Angle Flange (AFL), or Van Stone (VS).

Silencer

Ordering Information

- When ordering, specify material, gauge (if non-standard), dimension and end type.
- Reduces noise created by air movement inside the duct. Due to varying applications, no decibel testing has been performed on this product.
- Air flow directional arrow sticker is attached to product.

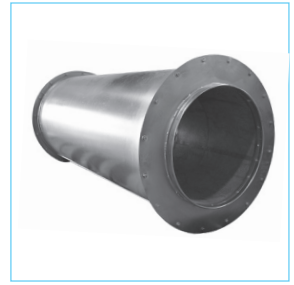

Ø in.	B OD in.	C Body Length in.	D (QF) in.	D (AFL/FLL) in.	Std Weight Lbs	
3	11	24	3.5 (for each end)		10	
4	12	24			21	
5	13	24			35	
6	14	26			43	
7	15	26			54	
8	16	31			65	
9	17	36			76	
10	18	44			89	
11	19	50			96	
12	20	50			104	
13	21	54			113	
14	22	54			122	
15	23	60			2 (for each end)	149
16	24				176	
17	25				201	
18	26		225			
19	27		245			
20	28		265			
21	29		288			
22	30		310			
23	31		358			
24	32		406			
26	34	546	4 (for each end)	N/A		
28	36	600				
30	38	678				
32	40	700				
34	42	770				
36	44	897				
38	46	974				
40	48	1118				

QF Material Options

	Galv (Collar)			SS (Collar)		
	Gauges	Size (in)		Gauges	Size (in)	
		Min. Ø	Max. Ø		Min. Ø	Max. Ø
Standard	20	3	16	20	3	16
	16	17	40	16	17	40

Flanged Material Options

	Galv (Collar)			SS (Collar)		
	Gauges	Size (in)		Gauges	Size (in)	
		Min. Ø	Max. Ø		Min. Ø	Max. Ø
Standard	20	3	16	20	3	16
	16	17	40	16	17	40

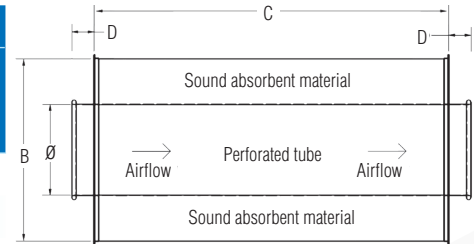

Construction

Collars: Caulked and painted.

Outer Tube: On 16" diameter pipe and all smaller sizes, longitudinal seam is laser welded. On 17" and greater, seam is plasma welded. The outer tube gauge is 20ga for sizes 3" - 16" and 16ga for sizes 17" and larger.

Cover Plate: Not intended to be removeable. 16ga construction.

Optional End Types: Standard QF end can be changed to Raw ID (RI), Raw OD (RO), No Fitting (NF), Hose Adapter (RF), Flat Flange (FLL), Angle Flange (AFL), or Van Stone (VS).

Suction Nozzle Assembly

Ordering Information

- Affix to end of hose for suction cleaning.
- 4" hose connection. Length = 21.



Ø in.	Std Weight Lbs
4	5.60

QF Material Options

	Galv		SS	
	Gauge	Size (in)	Gauge	Size (in)
Standard	22	4	22	4

Construction

Assembly consists of QF Reducer, Quick-Fit Sleeve, and QF Clamp.

Handle: 1018 carbon steel, painted

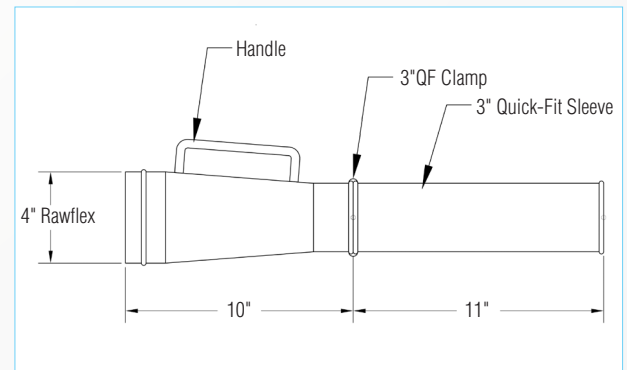

In Line Back Draft Damper

Ordering Information

- When ordering, specify material, gauge (if non-standard) dimension and end types.
- Used to reduce backward airflow in the line.
- Designed for use in a horizontal line. Specify if vertical operation is required.
- Not an explosion isolation device



Ø in.	Length in.	B Length in.	Std Weight Lbs
3	17.5	7	2.25
4	18.5	7	3.00
5	19.5	7	3.50
6	20.5	7	4.00
7	21.5	7	4.50
8	22.5	7	5.00
9	23.5	7	10.00
10	24.5	7	20.00
11	25.5	7	25.00
12	26.5	7	30.00
13	32.5	12	36.00
14	33.5	12	42.00
15	34.5	12	49.00
16	43.5	20	59.00
17	44.5	20	63.00
18	45.5	20	72.00
20	47.5	20	78.00
22	49.5	20	85.00
24	51.5	20	90.00
26	57.5	24	100.00
28	59.5	24	110.00
30	61.5	24	115.00
32	63.5	24	120.00
34	65.5	24	130.00

QF Material Options

Galv				SS			
Gauges	Size (in)		Gauges	Size (in)			
	Min. Ø	Max. Ø		Min. Ø	Max. Ø		
Standard	18	3	16	20	4	12	
	16 (Collar*)	18	24	18	13	24	
	14 (Body)			16	8	12	
Optional			Standard				

Flanged Material Options

Galv				SS			
Gauges	Size (in)		Gauges	Size (in)			
	Min. Ø	Max. Ø		Min. Ø	Max. Ø		
Standard	18	3	16	20	4	12	
	16 (Collar*)	18	32	18	13	34	
	14 (Body)			16	8	12	
	16 (Collar*)	34	34				
	12 (Body)						

* Collar and transition

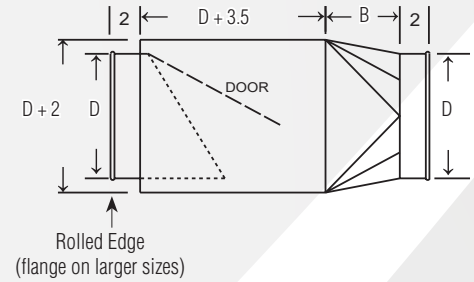

Construction:

Seam: lapped, spot welded, and caulked.

Collars: located on the exterior side of each port and considered as airflow non-directional. Collars have a laser welded longitudinal seam. If airflow directional product is required, it must be stated on the PO and additional cost may be incurred. A raised lap seam and spot weld are used for attaching the collar to the body and no caulking is used. If caulking is required, additional cost may be incurred.

Optional End Types

Standard QF end can be changed to Raw ID (RI), Raw OD (RO), No Fitting (NF), Flat Flange (FFL), Angle Flange (AFL), or Van Stone (VS).

**NOT AN
EXPLOSION ISOLATION DEVICE**

Ball Joint

Ordering Information

- When ordering, specify material, gauge (if non-standard) dimension and end type.
- Allows up to 22° of movement off-center. Ideal for machines with moving dust ports.
- Air flow directional arrow sticker is attached to product.
- **Odd sizes available upon request, with possibility of up to 6 weeks lead time.**



Ø in.	Length in.	Std Weight Lbs
4	9.5	10.19
5	10.75	15.18
6	11.75	17.13
7	10.75	19.23
8	14.0	21.36
9	15.0	23.3
10	14.25	26.59
12	15.25	28.86
14*	17.5	36.11

QF Material Options

	Galv		
	Gauges	Size (in)	
		Min. Ø	Max. Ø
All collars are 22ga for sizes 4" - 12", collar is 20ga for 14"			
Standard	20 (body)	4	7
	18 (body)	8	10
	16 (body)	12	12
	14 (body)	14	14

Not available in SS.

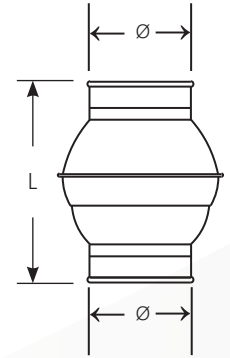

* 14" diameter - up to 6 weeks lead time

Bleed-in Valve

Ordering Information

- When ordering, specify material, gauge (if non-standard) dimension and end types.
- Used to adjust airflow to balance system by introducing ambient air.



Ø in.	Length in.	No. of Slots	Std Weight Lbs
3		4	3.75
4		4	4.00
5		6	4.25
6		6	4.50
7		8	4.75
8		8	5.00
9		10	5.25
10		10	5.50
11		10	5.75
12	11	12	6.25
13		12	6.75
14		14	7.50
15		14	8.25
16		16	10.00
17		16	11.75
18		18	13.50
20		20	15.00
22		22	18.00
24		24	22.00

QF / Flanged Material Options

	Galv			SS			
	Gauges	Size (in)		Gauges	Size (in)		
		Min. Ø	Max. Ø		Min. Ø	Max. Ø	
Standard	22	3	12	Standard	22	3	12
	20	13	24	Standard	20	13	24
Optional	18	4	24	Optional	18	8	24
	16	8	24		16	8	24

Construction

Seam: longitudinal seam is laser welded.

Collars: located on the exterior side of each port and considered as air flow non-directional. Collars have a laser welded longitudinal seam. If air flow directional product is required, it must be stated on the PO and additional cost may be incurred. A raised lap seam and painted spot weld are used for attaching the collar to the body and no caulking is used. If caulking is required, additional cost may be incurred.

Optional End Types: Standard QF end can be changed to Raw ID (RAWID), Raw OD (RAWOD), No Fitting (NF), Hose Adapter (RAWFLEX), Flat Flange (FFL), Angle Flange (AFL), or Van Stone (VANSTONE).

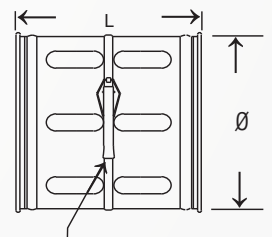

To adjust, loosen QF Clamp and turn outer sleeve to get proper airflow. Re-clamp when finished.

Butterfly Valve

Ordering Information

- When ordering, specify material, gauge (if non-standard), dimension and end types.
- A standard locking quadrant handle enables users to regulate air volumes in clean air applications.
- For clean air applications only.



Ø in.	Length in.	Std Weight Lbs
3	8	1.50
4	8	1.65
5	8	2.00
6	8	2.40
7	8	3.20
8	13	4.10
9	13	4.85
10	13	5.45
11	13	7.00
12	13	8.40
13	17	9.75
14	17	11.85
15	17	12.70
16	17	14.20
17	23	16.10
18	23	18.00
19	23	22.50
20	23	27.75
21	23	30.00
22	23	32.40
23	23	37.50
24	23	37.90

QF / Flanged Material Options

		Galv			SS		
		Size (in)			Size (in)		
Gauges		Min. Ø	Max. Ø	Gauges		Min. Ø	Max. Ø
Standard	22	3	12	Standard	22	3	12
	20	13	24		20	13	24
Optional	18	4	24	Optional	18	8	24
	16	8	24		16	8	24

Additional Product Components and Notes		
Quadrant (3/8" dial regulator)	Butterfly Valve Size	Mfr. Part No. (Duro Dyne)
	3" - 11" galvanized	KSR195L
	12" - 24" galvanized	KS385
	All SS	KR3SS



Temperature Rating: Max. temperature limited to 225°F due to the properties of the grommet (Styrene Butadiene Rubber, durometer hardness 60).

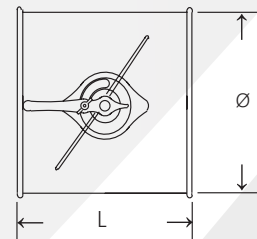

Viewing Spool

Ordering Information

- When ordering, specify material, gauge (if non-standard), dimension and end types.

- Air flow directional arrow sticker is attached to product.
- Section of acrylic glass with QF ends allowing user to view material flow through ductwork.

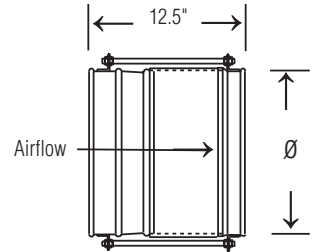

Ø in.	Length in.	Std Weight Lbs	
3	12.5	2.50	
4		3.00	
5		3.50	
6		4.10	
7		4.60	
8		5.00	
9		5.45	
10		6.25	
11		7.10	
12		8.20	
13		19.25	11.25
14		12.5	14.10
15	18.25		
16	22.60		
18	18.00		

QF / Flanged Material Options

Galv				SS			
Gauges	Size (in)		Gauges	Size (in)			
	Min. Ø	Max. Ø		Min. Ø	Max. Ø		
Standard	22	3	12	22	3	12	
	20	14	18	20	14	18	
Optional	18	4	18	18	8	18	
	16	8	18	16	8	18	

Construction

Seam: longitudinal seam is laser welded.

Collars: Collars have a laser welded longitudinal seam.

Acrylic: Acrylite® - clear, .250 thick

Optional End Types: Standard QF end can be changed to Raw ID (RI), Raw OD (RO), No Fitting (NF), Hose Adapter (RAWFLEX), Flat Flange (FFL), Angle Flange (AFL), or Van Stone (VS).



Temperature Rating: Max. temperature limited to 225°F due to properties of the acrylic viewing port.

Sliding Access Panel

Ordering Information

- When ordering, specify material, gauge (if non-standard) dimension and end type.
- Allows access without removal of duct.

- Length equals nominal pipe length. Cannot be made shorter than 36".
- 6"-24" units have 7" x 14" access hole.

Ø in.	Pipe Length in.	Slide Length in.	Access Hole	Std Weight Lbs
6	59.25	18	7 x 14	10.19
7	59.06			15.18
8	59.06			17.13
9	58.75			19.23
10	58.75			21.36
11	58.75			23.3
12	58.75			26.59
13	58.75			28.86
14	58.75			36.11
15	58.75			38.56
16	58.75			41.00
17	58.75			43.48
18	58.75			44.99
20	58.75			49.94
22	58.75			54.88
24	58.75			59.92

QF / Flanged Material Options

Galv				SS			
Gauges	Size (in)		Gauges	Size (in)			
	Min. Ø	Max. Ø		Min. Ø	Max. Ø		
Standard	22	6	12	22	6	12	
	20	13	24	20	13	24	



Construction

Collars: have a laser welded longitudinal seam.

Optional End Types: Standard QF end can be changed to Raw ID (RAWID), Raw OD (RAWOD), No Fitting (NF), Hose Adapter (RAWFLEX), Flat Flange (FFL), Angle Flange (AFL), or Van Stone (VANSTONE).

Floor Sweep

Ordering Information

- When ordering, specify material, gauge (if non-standard), dimension and end type.
- Galvanized or SS (optional) sheet metal with sturdy closing door.
- Quick and effective floor cleaning.
- Body 20 gauge, door 16 gauge.



Ø in.	Std Weight Lbs
3	5.80
4	6.90
5	7.30
6	7.55
7	7.75
8	8.25
9	9.50
10	11.75
11	13.20
12	15.70

QF / Flanged Material Options

Gauges	Galv			SS			
	Size (in)			Size (in)			
	Min. Ø	Max. Ø		Min. Ø	Max. Ø		
Std	20	3	12	Std	20	3	12
Optional	18	4	12	Optional	18	8	12
	16	8	12	Optional	16	8	12

*Other gauges available

Construction

Body: lapped, spot welded and caulked.

Collar: has a laser welded longitudinal seam. Collar is attached to the body using a raised hemmed, spot welded seamed construction.

Door: 16ga.

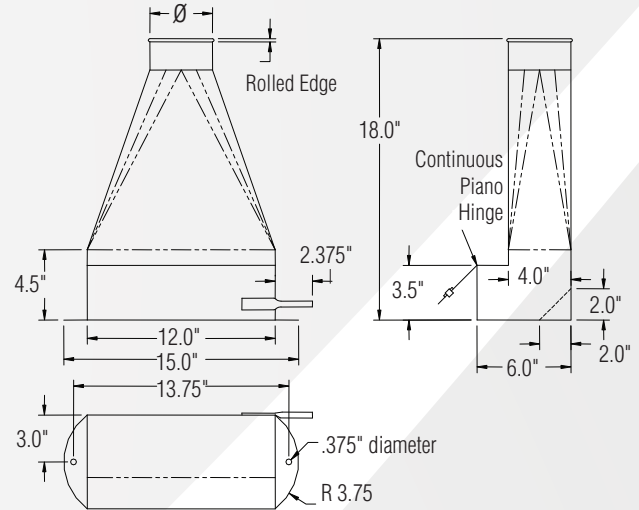

Drop Out Box

Ordering Information

- When ordering, specify material, gauge (if non-standard), dimension and end type.
- The Drop Out Box stops large wood chips in the airstream. Inside the duct, deflectors knock chips downward into the built-in hopper.



Ø in.	Outlet Ø in.	Length in.	Height in.	Std Weight Lbs
6	4	44	20.25	60
7	4		20.75	64
8	6		21.25	69
9	6		21.75	75
10	8		22.25	80
11	8		22.75	85
12	10		23.25	89
14	12		24.25	96
16	14		25.25	106

Other sizes available upon request

QF / Flanged Material Options

Gauges	Galv		
	Size (in)		
	Min. Ø	Max. Ø	
Standard	14 (collar 18ga on 6 and 7 inch sizes)	6	16

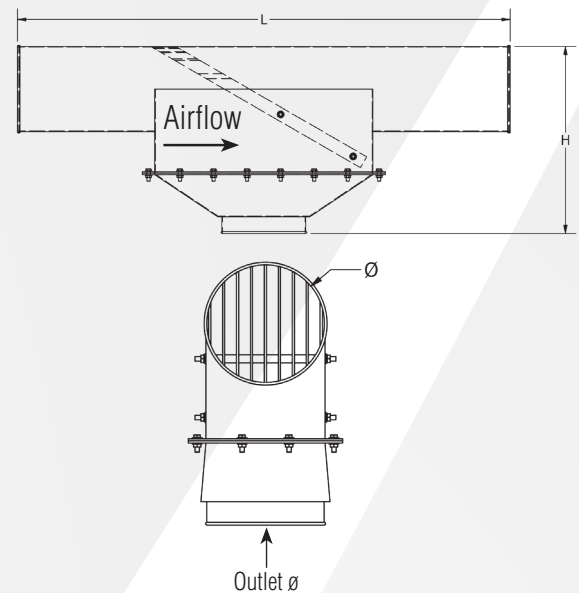

Vibration Isolator ◊

Ordering Information

- When ordering, specify material, gauge (if non-standard), dimension and end type.

- Air flow directional arrow sticker is attached to product.
- Reduces vibration from the fan to the ducting system.

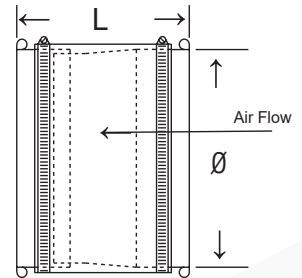

Ø in.	Length in.	Std Weight Lbs	
3	6.5	1.50	
4		2.00	
5		2.30	
6		2.90	
7		3.45	
8		3.80	
9		4.20	
10		4.80	
11		5.10	
12		5.60	
13		6.00	
14		7.60	
15		7.10	
16		8.60	
17		9.35	
18		10.15	
20		12.40	
22		14.90	
24		7	17.60

QF / Flanged Material Options

Galv				SS			
Gauges	Size (in)		Gauges	Size (in)			
	Min. Ø	Max. Ø		Min. Ø	Max. Ø		
Standard	22	3	12	22	3	12	
	20	13	24	20	13	24	
Optional	16	8	24	Optional	16	8	24

Construction

Collars: have a laser welded longitudinal seam. Collars are attached to the body using a raised hemmed, spot welded seamed construction and are caulked.
Hose Clamps are used on ends to secure rubber to metal ends.
Optional End Types: Standard QF end can be changed to Raw ID (RI), Raw OD (RO), No Fitting (NF), Hose Adapter (RF), Flat Flange (FFL), Angle Flange (AFL), or Van Stone (VS).



Temperature Rating: Minimum (-40°) and maximum (194°) operating temperatures are limited by the properties of the rubber component.

◊ Items may take longer than standard lead times.

In-line Spark Trap

Ordering / Installation Information

- When ordering, specify material, gauge (if non-standard), dimension and end type.
- Greatly reduces the possibility of fire in cyclones / collectors by decreasing the number of sparks which could reach these through the air handling system. This is accomplished by disrupting the laminar airflow to cause sparks to cool and extinguish before they can enter the dust collector / cyclone. The Spark Trap does not replace spark detection or explosion isolation devices; it is a complementary device to existing detection and suppression equipment.
- No moving parts and no power required for operation.
- Airflow Velocity: 1500-5000 fpm (7.62m/sec - 25.4m/sec)
- Duct distance recommended: At least ten diameters from dust collector / cyclone and the source (example: 8" duct line, recommended distance is min. 80")
- IMPORTANT: Horizontal mounting only.



Not an explosion isolation device

Ø in.	Width nom. in.	Height nom. in.	Std Weight Lbs
4	18	7	6
5	20	9	7
6	20	10	8
7	22	12	11
8	22	13	13
9	24	15	15
10	24	16	16
11	26	18	19
12	26	19	21
13	28	21	23
14	28	22	26
16	30	25	33
18	32	28	47
20	34	31	58
22	38	35	72
24	40	38	87

QF / Flanged Material Options

		Galv			SS		
		Size (in)			Size (in)		
		Gauges	Min. Ø	Max. Ø	Gauges	Min. Ø	Max. Ø
Standard		22	4	12	22	4	12
		20	13	24	20	13	24
Optional		20	4	6	18	8	24
		18	7	24			



Temperature Rating: Each In-line Spark Trap, sizes 4" - 14", includes a QF clamp to attach the two sections together. If your application requires materials rated for temperatures consistently higher than 158°F, please specify the optional ePTFE seal available for the clamp, which allows application up to 600°F. Larger Spark Traps are attached via standing seam without QF Clamps.

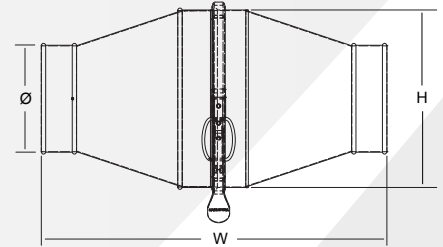

Drawing above illustrates construction of Spark Traps in sizes 4" - 14".

Drawing below illustrates construction of Spark Traps in sizes 16" - 24".

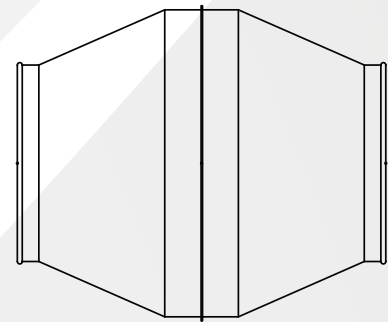

Construction

Seam: longitudinal seam is laser welded.

Collars: Collars have a laser welded longitudinal seam which are also caulked and painted.

Optional End Types: Standard QF end can be changed to Raw ID (RAWID), Raw OD (RAWOD), No Fitting (NF), Flat Flange (FLL), Angle Flange (AFL), or Van Stone (VANSTONE).

Notes: The exterior is available in optional materials, as shown above, but the internal components must remain standard.

Spark Traps, sizes 4" - 14", are sold only as a complete unit, which includes two sections and a clamp attaching the sections. Diameter of both ends must be the same measurement (i.e. if diameter of airflow side is 6", diameter of downstream side must also be 6".)

Spark Traps, sizes 16" - 24", are sold only as a complete unit, which includes two sections attached via standing seam. These sizes cannot be disassembled.

Clamps are not available in 316SS

The Nordfab In-line Spark Trap is a simple, low-cost tool that can reduce incidents of fire events, reducing costs and disruption and improving safety. System redundancy and complementary measures should be applied. It is not a primary safety device and does not replace spark detection or explosion isolation devices.

Our Pressure Loss Test Results	
Ø in.	Airflow at 3000 FPM prior to Spark Trap (w.g.)
4	-0.85
5	-0.85
6	-0.90
7	-1.00
8	-1.10
9	-1.10
10	-1.20
12	-1.35
14	-1.45
16	-1.20
18	-1.20
20	-1.25
22	-1.20
24	-1.25

Nordfab Sealed Duct System (QFS)

Nordfab's QFS system consists of three parts: QFS Sealant, Gaskets and O-rings

A sealed duct system is largely dependent on the skill and care of the installer, so Nordfab cannot guarantee a 100% leak free system. However, if users consult the technical data (to ensure that our gasket and sealing materials will stand up to the materials being conveyed) and take care in the installation process, this system has proven that it can be 'Leak Free'.



QFS Molded Gasket

Ordering / Installation Information

- When ordering, specify size. Order one gasket per duct join.
- Conductive material
- General purpose oil resistant polymer. Performs well in many oil, water and hydraulic fluid applications.
- Should not be used with solvents such as acetone, MEK, ozone, chlorinated hydrocarbons, and nitro hydrocarbons.
- Temp range: -30° F to 225° F.
- Classification: ASTM D-2000 M2BG510 A24 B34 E014 E034 EF11 EF21

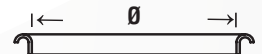

Size (in)	
Min. Ø	Max. Ø
3	24

QFS O-ring

Ordering / Installation Information

- When ordering, specify size.
- Performs well with many oils and chemicals.
- Can't be damaged by flexing and twisting.
- This O-Ring works in conjunction with Nordfab's standard O-ring. IT DOES NOT REPLACE IT.
- Temp range: -30° F to 225° F.

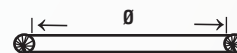
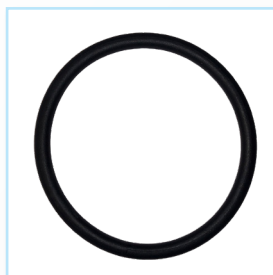

Size (in)	
Min. Ø	Max. Ø
3	24

QFS Sealant

Ordering / Installation Information

- Available for all parts without solid welds.
- UV resistant. Good to excellent resistance to most solvents, acids, oils, and alkalides.
- Temp range: -40° F to 190° F.



Oil Mist Recycler

Ordering / Installation Information

- When ordering, specify material, gauge (if non-standard), dimension and end type.
- Extracts oil to minimize amount of oil flowing through entire system.
- Installs in vertical or horizontal applications.
- Consists of recycler unit, molded gasket, clamp and end cap.
- 5' clear hose and hose clamp provided for drain tap.

Ø in.	Length in.	Height in.	Baffle Size in.	Std Weight Lbs
3	14	18	10 x 14	11.10
4	14	18	10 x 14	11.25
5	14	18	10 x 14	11.45
6	14	18	10 x 14	11.60
7	20	24	16 x 20	22.70
8	20	24	16 x 20	22.85
9	20	24	16 x 20	23.10
10	20	24	16 x 20	23.30
12	20	28	20 x 20	32.85

 **Temperature Rating:** -30° F to +225° F

QF / Flanged Material Options

Galv				SS			
Gauges	Size (inches)		Gauges	Size (inches)			
	Min. Ø	Max. Ø		Min. Ø	Max. Ø		
Std	22	3	12	Std	22	3	12
Optional	20	3	12	Optional	20	3	12
	18	4	12		18	8	12
	16	8	12		16	8	12

Construction

Constructed of 22ga thick galvanized or SS, with lapped, spot welded, and epoxy caulked seams. The main body of the unit includes an end cap, clamp, and molded gasket for internal access and maintenance. Product can be mounted in vertical or horizontal applications and includes 5' of clear PVC tubing and hose clamp for the drain fitting.

Optional End Types: Standard QF end can be changed to Raw ID (RI), Raw OD (RO), No Fitting (NF), Hose Adapter (RF), Flat Flange (FFL), Angle Flange (AFL), or Van Stone (VS).

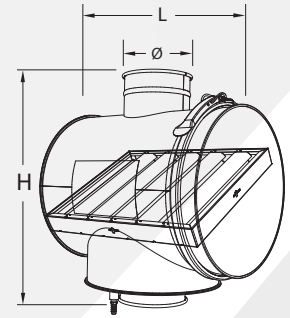

Vertical Installation

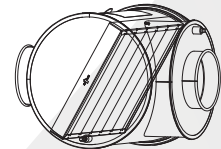

Horizontal Installation

Oil Mist Drain Back for Hose

Ordering / Installation Information

- When ordering, specify material, gauge (if non-standard), dimension and end type.
- Connected to hose, the Drain Back returns oil to the ducting line and helps prevent oil from leaking onto machinery.

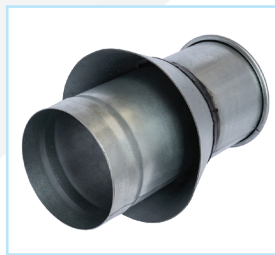

Ø in.	Length in.	Std Weight Lbs
3	11.5	1.5
4	8.5	1.9
5	8.5	1.3
6	8.5	2.8
7	8.5	3.4
8	8.5	3.8
9	8.5	4.4
10	8.5	4.9
11	8.5	5.3
12	8.5	5.8

QF / Flanged Material Options

Galv				SS			
Gauges	Size (inches)		Gauges	Size (inches)			
	Min. Ø	Max. Ø		Min. Ø	Max. Ø		
Std	22	3	12	Std	22	3	12
Optional	20	3	12	Optional	20	3	12
	18	4	12		18	8	12
	16	8	12		16	8	12

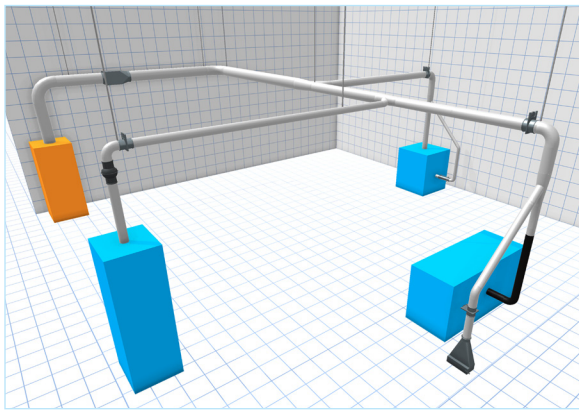

Sizing a QF Duct System

Nordfab offers assistance to salespeople and customers who have never designed a ducting system. We can provide 3D designs that allow you to visualize the ductwork in your facility and assist you in determining the correct pipe size and configuration which will supply you with the correct flow. Please contact Nordfab for assistance.

EXAMPLE: Always work from your machines back toward the filter. Suppose that you have a 5" drop that rises and runs back to join with a 6" drop as sketched above. What size branch will you need?

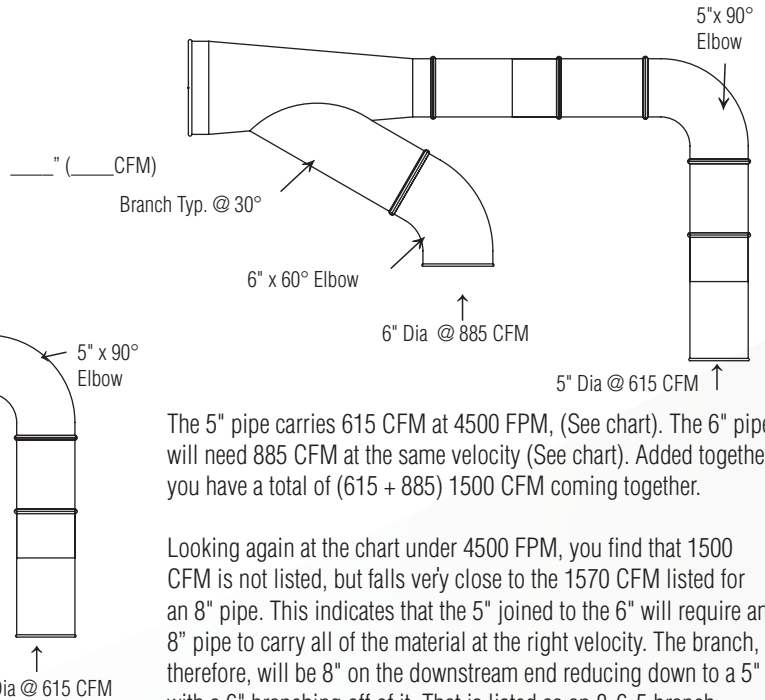

The 5" pipe carries 615 CFM at 4500 FPM, (See chart). The 6" pipe will need 885 CFM at the same velocity (See chart). Added together you have a total of (615 + 885) 1500 CFM coming together.

Looking again at the chart under 4500 FPM, you find that 1500 CFM is not listed, but falls very close to the 1570 CFM listed for an 8" pipe. This indicates that the 5" joined to the 6" will require an 8" pipe to carry all of the material at the right velocity. The branch, therefore, will be 8" on the downstream end reducing down to a 5" with a 6" branching off of it. That is listed as an 8-6-5 branch.

Air Volume Chart

USING THE CFM/FPM CHART

This chart allows you to choose the correct pipe size for the CFM that is required. Different materials need to be conveyed at different velocities to prevent the material from falling out of the air stream.

For example, wood chips and saw dust flow well at 4500 feet per minute. Referring to the chart, a 4" pipe will convey 395 CFM at 4500 FPM. This indicates that a 4" pick-up on a machine will use 395 CFM from the filtering system.

Or working in reverse, if you know that a machine will require approximately 400 CFM to remove the waste, then you should design a 4" pipe for the application.

AIR VOLUME IN DUCTS IN CUBIC FEET PER MINUTE (CFM)											
DUCT Ø	VELOCITY IN FEET PER MINUTE (FPM)										
	2000	2500	3000	3500	4000	4500	5000	5500	6000	6500	7000
3	100	125	150	170	195	220	245	270	295	320	345
4	175	220	260	305	350	395	440	485	525	570	615
5	275	340	410	475	545	615	680	750	820	885	955
6	395	490	590	685	785	885	980	1080	1180	1275	1375
7	535	670	800	935	1070	1205	1335	1470	1605	1735	1870
8	700	875	1050	1220	1395	1570	1745	1920	2095	2270	2445
9	885	1105	1325	1545	1765	1990	2210	2430	2650	2870	3090
10	1090	1365	1635	1910	2180	2455	2725	3000	3270	3545	3820
11	1320	1650	1980	2310	2640	2970	3300	3630	3960	4290	4620
12	1570	1965	2355	2750	3140	3535	3925	4320	4710	5105	5500
13	1850	2300	2770	3225	3685	4150	4610	5070	5530	5990	6450
14	2140	2675	3205	3740	4275	4810	5345	5880	6415	6950	7485
15	2450	3070	3680	4300	4900	5520	6130	6750	7360	7970	8590
16	2790	3490	4190	4885	5585	6285	6980	7680	8380	9075	9775
17	3150	3940	4730	5515	6300	7090	7880	8670	9450	10240	11030
18	3535	4420	5300	6185	7070	7950	8835	9720	10600	11485	12370
20	4365	5455	6545	7635	8725	9815	10910	12000	13090	14180	15270
22	5280	6600	7920	9240	10560	11880	13200	14520	15840	17160	18480
24	6285	7855	9425	10995	12655	14315	15710	17280	18850	20420	21995
26	7370	9210	11055	12900	14740	16580	18420	20270	22110	23950	25800
28	8550	10685	12820	14960	17100	19230	21310	23500	25650	27780	29920
30	9800	12260	14700	17170	19625	22080	24530	26990	29440	31890	34350
32	11160	13950	16750	19541	22330	25120	27910	30700	33490	36302	39070
34	12600	15755	18905	22055	25210	28360	31510	34660	37810	40965	44115
36	14130	17665	21195	24730	28260	31800	35325	38860	42390	45925	49455
38	15745	19680	23615	27550	31490	35425	39360	43295	47230	51170	55100
40	17445	21800	26170	30530	34890	39250	43610	47975	52330	56700	61055

Installation Tips



STEP ONE: Make Sure Your Shipment is Complete and Undamaged. Nordfab ships most orders FOB Nordfab or “Free On Board.” **This means that it is your responsibility to ensure that the materials you receive do not have freight damage and that the carrier has delivered all the boxes in your shipment.**

Inspect all boxes for outward damage BEFORE signing for receipt. The boxes should be strapped to a pallet, and not be crushed, torn, or otherwise damaged. **If you find damage, either refuse the shipment or note the issue on the receipt you sign. Unless you do this, any future claims will be virtually impossible to collect.**

Additionally, before signing for your shipment, ensure that all boxes are accounted for. You can find the number of boxes in a shipment by checking the delivery receipt the driver will ask you to sign. Again, note any discrepancies before signing. **IMPORTANT SAFETY NOTE:** Beware of the sharp metal staples used to seal the shipping boxes.

STEP TWO: Understanding the Packing Documents. Nordfab packs boxes with the goal of reducing shipping costs, not in the order the parts are needed. Do not simply tear into the boxes and begin removing parts. On the outside of each box is a label that shows the contents. Locate these labels before opening any boxes as it will give you details as to what is in each box. Avoid opening a box until you need its contents, to reduce the chance of parts being lost or damaged on site. If you have any problems, call your dealer as he is in the best position to rectify any problems with your particular order. Have all packing documentation with you when you call.

STEP THREE: Preparing to Install Your Ducting. It is important for the installer to understand the layout that the system designer planned for the ducting. Follow all local codes and regulations and note loading capabilities of structures to ensure the ducting is properly supported and that the building can carry the ducting system. If your installer doesn't understand the layout, he will not have all the parts necessary to complete the job. If you do not have a clear understanding or drawing of the system you are about to install, please call the person who designed the system before you begin work.



STEP FOUR: Laying out the duct. Begin by laying the system out on the floor below where it will hang. Remember that two parts that connect will often not be in the same box, so this step dramatically reduces the time it takes to complete the job once the installation begins.

NOTE: This is the step where you could possibly find that you do not have all the parts necessary to complete the job. In that case, contact your dealer immediately so that he can get a head start on getting the needed parts to you as well as help you verify that your layout matches the one planned by the system designer.

STEP FIVE: The Quick-Fit Sleeve (adjustable nipple). One of the most important benefits of Quick-Fit® is that it is not necessary to take exact measurements before cutting each piece of pipe. The Quick-Fit Sleeve is an 11-inch section of pipe that has a slightly larger diameter than a standard QF duct.

STEP SIX: Supporting Your Ductwork. Nordfab has a variety of duct hanging devices, but it is your responsibility to ensure the safety of all ducting. Please check with local agencies to ensure that your ducting is supported in a way that meets local codes. When determining the weight that your ceiling and hangers must support, always allow for the ducting being 100% clogged with whatever material is being conveyed.

STEP SEVEN: Pre-Stretch Your Clamps. Nordfab QF Clamps are designed to provide a tight seal, which means that they also require some pressure to close. By pre-stretching the clamp around the rolled edge of a single piece of pipe, you can make it much easier to close when you connect two pieces together.

STEP EIGHT: Clamp As Many Parts Together As Possible on the Ground. It is much faster and easier to close the clamps on stable ground than on a scaffold. Therefore, many installers connect two or three pieces of ductwork together on the floor before lifting them into place.

STEP NINE: Use the Cotter Pins. After closing each clamp, install one of the enclosed cotter pins into the hole as shown. This ensures that the clamp cannot come open unexpectedly. Install the cotter pin as soon as a clamp is closed and beware of clamps until the cotter pin is safely installed.

IMPORTANT SAFETY NOTE: On very rare occasions, unpinned clamps can spring open unexpectedly which can cause the pipe to drop. Additionally, the handles on unpinned clamps have been known to cause injury when they sprang open.

Useful Tools and Important Safety Information:

Always use proper safety equipment when installing Quick-Fit®

- Work Gloves
- Safety Helmet
- File
- Level
- Eye & Ear Protection
- Cutting Device
- Scaffolding
- Plumb



Use Cotter Pins

Parts List Take-off Worksheet

QF Ø in	Pipe	Quick-Fit® Sleeves w/ O-Ring	Elbows				Machine	Adapters		Hose	Blast Gates		Hose: Rubber or Steel	Hose Clamps	QF Clamps	Misc. Fittings (Reducers, Adapters, Transitions, etc.)	Branches: Standard, Double Branch, Y Branch				Degree	Quantity		
			90°	60°	45°	30°		Angle Flange	Flange		Man	Auto					A	B	C	D				
3																								
4																								
5																								
6																								
7																								
8																								
9																								
10																								
11																								
12																								
13																								
14																								
15																								
16																								
17																								
18																								
19																								
20																								
21																								
22																								
23																								
24																								
AFL Ø in	Pipe	Flange Gaskets	Elbows				Machine	Adapters		Hose	Blast Gates		Hose	Hose Clamps	Angle Flanges	Misc. Fittings				Branches				Quantity
			90°	60°	45°	30°	Angle Flange	Flange	Man	Auto	Hose	Hose	Hose	Clamps	Angle Flanges	Misc. Fittings				Branches				Quantity

Shipping Details

LTL (Less Than Truckload) Shipments

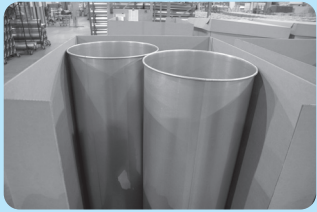

LTL carriers have “minimum” charges. So one or two parts in a box may be the most economical and safest way to package them.

- LTL carriers have a minimum charge of all orders less than 150 pounds. So when you order one or two parts, you may be surprised when they arrive strapped to a whole pallet or in one very large box. We have found that this method reduces the instances for damage – without increasing the costs.

- While it is possible and economical to strap items to the top of large boxes, it is not standard practice for two reasons:

a) The instance of damage increases dramatically.

b) We can easily load these boxes at our level docks. However, customers have found it very difficult to unload trucks at the job site where there is no guarantee of a level dock or an experienced forklift driver.



It is possible to stack some items on top of boxes, but it can lead to damage and problems when unloading the shipment.



Oversized or loose items can affect shipping rate.

- Sometimes it is possible and safe to stack items or boxes on top of our standard cartons, so we can use this method to save shipping costs. HOWEVER, it is up to you to let us know when this stacking is unacceptable and it is up to you to work with the freight companies to get reimbursement for any damaged items.
- There is an additional charge for any item that is too large to fit on a standard pallet. This includes loose items not attached to any pallet. Also, we know from experience that having an item “hang over” the edges of the pallet is a recipe for freight damage, so we use larger pallets (at the higher rate) when necessary. NOTE: a standard skid is 40" X 48" X 65" tall.
- When possible, Nordfab “nests” smaller pipe inside larger pipe to save space. We have learned from experience that this is not always practical. If the smaller diameter pipe is dramatically smaller than the pipe it nests into, or if the smaller pipe is flanged, then there is a high probability that both pipes will be damaged in shipment.

- Occasionally dealers send several different orders to the same address on the same day. You can save money by having Nordfab package multiple orders onto a single pallet. The individual boxes will be marked with the order number. This multiple packaging can cause confusion on site, so it is not our standard practice. If you want multiple orders packaged together it must be noted on your purchase order FOR ALL ORDERS TO BE PACKAGED TOGETHER.
- NOTE, you may be able to save even more on shipping if you instruct us NOT to separate the orders. For example, if pipe for three different orders is nested together, it takes up much less room than having three sets of pipe separated into separate compartments. However, this method requires the parts to be separated on site.
- No LTL shipment should exceed more than SIX pallets or our discount is eliminated and an expensive “flat rate per mile” fee is charged. For this reason, if your order contains more than six pallets, we will split it into multiple shipments or use a dedicated trucking company. Splitting up shipments causes a bit of extra paperwork for us, and you’ll need to inform the people who receive your shipments on site. But the extra work is worth the savings.



Nested Pipe

Nordfab packages items in the most economical manner, based on experience.

UPS Shipments

- Unlike standard LTL shipments, UPS does charge by the size of the box, so Nordfab always cuts boxes down as small as practical when shipping via UPS.
- The largest pipe we can ship economically via UPS is 14". The largest elbow is a 14" 90° elbow.
- The largest volume box we can ship economically via UPS is 24" X 24" by 24".
- When you need next day delivery, specify WHEN you need the item on site. There are three levels of UPS Red service for most shipping points (delivered by 8:30 a.m., 10:30 a.m., or 5:00 p.m.). The later the delivery, the less the cost. Nordfab’s default is 10:30 a.m. If you need the product earlier - or can accept it later- please let us know. If you don’t need the part until the afternoon, shipping costs will be slightly cheaper.

Return Material Authorization Chart

304SS

Galvanized

Ø INCHES	Pipe	Quick-Fit Sleeve incl. O-Ring	Elbows				Blast Gate Manual	Blast Gate NFES Automatic	Machine Adapter, Standard is QF to ID	Hose Adapter	Angle Flange Adapter	QF Clamp	Pipe Hanger	O-Ring BLACK	O-Ring RED	Pipe	Quick-Fit® Sleeve Incl. O-Ring	QF Clamp	Hose Clamp
			Standard Radius		Long Radius														
			90°	60°	45°	30°	90°	Std											
3	0	0	0	0	0	0	0	0	0	0	0	0	0	0	0	0	0	0	0
4	0	0	0	0	0	0	0	0	0	0	0	0	0	0	0	0	0	0	0
5	0	0	0	0	0	0	0	0	0	0	0	0	0	0	0	0	0	0	0
6	0	0	0	0	0	0	0	0	0	0	0	0	0	0	0	0	0	0	0
7	0	0	0	0	0	0	0	0	0	0	0	0	0	0	0	0	0	0	0
8	0	0	0	0	0	0	0	0	0	0	0	0	0	0	0	0	0	0	0
9	0	0	0	0	0	0	0	0	0	0	0	0	0	0	0	0	0	0	0
10	0	0	0	0	0	0	0	0	0	0	0	0	0	0	0	0	0	0	0
11	0	0	0	0	0	0	0	0	0	0	0	0	0	0	0	0	0	0	0
12	0	0	0	0	0	0	0	0	0	0	0	0	0	0	0	0	0	0	0
13	0	0	0	0	0	0	0	0	0	0	0	0	0	0	0	0	0	0	0
14	0	0	0	0	0	0	0	0	0	0	0	0	0	0	0	0	0	0	0
15	0	0	0	0	0	0	0	0	0	0	0	0	0	0	0	0	0	0	0
16	0	0	0	0	0	0	0	0	0	0	0	0	0	0	0	0	0	0	0
17	0	0	0	0	0	0	0	0	0	0	0	0	0	0	0	0	0	0	0
18	0	0	0	0	0	0	0	0	0	0	0	0	0	0	0	0	0	0	0
20	0	0	0	0	0	0	0	0	0	0	0	0	0	0	0	0	0	0	0
22	0	0	0	0	0	0	0	0	0	0	0	0	0	0	0	0	0	0	0
24	0	0	0	0	0	0	0	0	0	0	0	0	0	0	0	0	0	0	0

0 = Returnable item
Nordfab reserves the right to limit quantities of any returned items

There is a 25% restocking charge for all returned goods.
All components must arrive in "as-new" sealable condition.
Final determination of self-ability will rest solely with Nordfab.

Branches	Reducers	Grippler Hangers
Galv Branch QF Standard 6-4-4 30°	Galv Reducer 5-4	Size Weight Up to 22 lbs
Galv Branch QF Standard 6-6-4 30°	Galv Reducer 6-4	Up to 100 lbs
Galv Branch QF Standard 6-6-6 30°	Galv Reducer 6-5	Up to 200 lbs
Galv Branch QF Standard 8-6-6 30°	Galv Reducer 7-4	Up to 495 lbs
Galv Branch QF Standard 8-6-6 30°	Galv Reducer 7-5	Up to 715 lbs
Galv Branch QF Standard 8-8-8 30°	Galv Reducer 7-6	
	Reducer 8-4	
	Reducer 8-5	
	Reducer 8-6	
	Reducer 8-7	

Catalog is subject to change without notice
General Conditions of Sale apply
Product photographs reference only

Published lengths are nominal and may vary slightly
All photos are property of Nordfab Ducting
Nordfab®, Quick-Fit®, and QF® are registered trademarks owned by Nordfab

Nordfab Americas: Terms & Conditions of Sale

Effective April 22, 2020

GENERAL TERMS

These Terms & Conditions of Sale (these "Terms") shall govern all conduct between the Buyer and Nordfab, LLC ("Nordfab") regardless of the nature or form of Buyer's offer to purchase products or services from Nordfab (the "Products"). To the extent a Nordfab order acknowledgement, invoice or other document or transmittal constitutes an acceptance of an offer from Buyer, such acceptance is expressly made conditional upon Buyer's assent to these Terms. "Buyer" means the individual or entity identified on Buyer's purchase order, or if different, on Nordfab's quote.

The entire agreement of Nordfab and Buyer is expressed exclusively in: (i) the terms, covenants and conditions set forth in these Terms, (ii) the drawings, specifications and descriptions attached hereto or transmitted herewith (if any) (collectively, the "Documentation"), (iii) a Nordfab quote and (iv) Nordfab's acceptance or acknowledgement of Buyer's purchase order (clauses (iii) and (iv) together, an "Order"). In the event that any quotation, proposal, purchase order, order acknowledgement, order acceptance and/or other sales form or documentation contains terms which are in addition to, different from or inconsistent with those set forth in these Terms, these Terms shall be controlling and any such additional, different or inconsistent terms and conditions shall be inapplicable and are hereby objected to. Receipt and acceptance by Buyer of Products supplied by Nordfab shall constitute Buyer's acceptance and assent to these Terms. Buyer should print and retain a copy of these Terms for its records.

These Terms shall be governed, construed, and enforced in accordance with the laws of the State of North Carolina, excluding that State's conflict of law principles, as to all matters arising out of or relating to these Terms. Nordfab and the Buyer exclude the application of the 1980 United Nations Convention on Contracts for the International Sale of Goods if otherwise applicable. Any claim, or litigation arising out of or relating to the Products shall be brought exclusively in a court of competent jurisdiction in Davidson County, North Carolina.

Nordfab and Buyer may modify these Terms, or the associated Order, only by an express written agreement signed by both parties. Nordfab's waiver of any breach of any provision contained in these Terms will not waive any other breach by Buyer. Nordfab's delay or failure to enforce its rights under these Terms shall not be deemed a waiver of such rights. Except for Buyer's payment and indemnification obligations, neither party shall be liable for its failure to perform any obligation hereunder or under any Order to the extent that such failure results from circumstances beyond such party's reasonable control, including, without limitation, fire, explosion, flood, or other acts of God; acts, regulations, or the laws of any government; plague, epidemic, pandemic, outbreaks of infectious disease or any other public health crisis (including quarantine or other employee restrictions); riot, war or civil commotion; acts of terrorism; strike, lock-out or labor disturbances; or failure of public utilities or common carriers. The relationship between the parties is that of independent contractors. Neither party shall have authority to contract for or bind the other party in any manner whatsoever. Any part of these Terms held to be invalid or unenforceable by a tribunal of competent jurisdiction shall be deemed ineffective to the extent thereof without affecting the validity or enforceability of any other part of these Terms. Provisions of these Terms which by their nature should apply beyond their terms will remain in force after any termination or expiration of these Terms.

These Terms are binding upon, and shall inure to the benefit of Buyer, Nordfab and their successors and permitted assigns. Buyer may not assign all or any portion of its rights or obligations hereunder without the prior written consent of Nordfab. Nordfab may assign, delegate or subcontract an Order or any of its obligations under these Terms, in whole or in part, without Buyer's consent.

LIMITED WARRANTY

Nordfab warrants that the Products sold hereunder conform to any applicable Documentation and will be free from any defects in material and workmanship which become apparent under normal use. This limited warranty applies to the original Buyer only and is non-transferable. To make a claim under this limited warranty, Buyer must give written notice to Nordfab within a period of 12 months from the date of installation or 12 months from the date of shipment, whichever period first expires. If, within that period, Nordfab receives from Buyer written notice of any alleged defect in or non-conformance of any Product covered by this limited warranty and if, in Nordfab's sole judgment, the Product does not conform with this limited warranty, then Buyer shall, at Nordfab's request, return the part or Product F.O.B. Nordfab's shipping point. Nordfab, at its sole option and expense, shall then repair or replace the defective part or Product or repay Buyer the full price paid for such part or Product. Dismounting of defective or non-conforming parts and remounting of any repaired or replaced parts is at Buyer's sole expense. This limited warranty, as it relates to the delivery of spare parts or replacement for non-conforming parts, expires when the limited warranty for the original Product or equipment expires. Any repayment of the purchase price shall be without interest. **NORDFAB'S SOLE RESPONSIBILITY, AND BUYER'S EXCLUSIVE REMEDY HEREUNDER, SHALL BE LIMITED TO SUCH REPAIR, REPLACEMENT, OR REPAYMENT OF THE PURCHASE PRICE AS ABOVE PROVIDED. NO OTHER WARRANTIES, EXPRESS, STATUTORY, OR IMPLIED, ARE MADE AND ANY AND ALL IMPLIED WARRANTIES OF MERCHANTABILITY, QUALITY, OR FITNESS FOR PARTICULAR PURPOSE ARE EXPRESSLY DISCLAIMED.** This limited warranty does not cover and Nordfab makes no warranty with respect to:

- A) failures not reported to Nordfab within the warranty period specified above;
- B) failure or damage due to misapplication, abuse, improper installation or abnormal conditions of any kind, including, but not limited to, temperature, dirt or other corrosive matter;
- C) failures due to operation, either intentional or otherwise, above rated capacities or in an otherwise improper manner;
- D) Products which have been in any way tampered with or altered by anyone other than an authorized representative of Nordfab;
- E) Products damaged in shipment or otherwise without fault of Nordfab;
- F) expenses incurred by Buyer in an attempt to repair, rework, or replace any alleged defective Product; and
- G) defects in material and workmanship which are attributable to drawings and specifications provided by Buyer.

TERMS OF PAYMENT

Unless agreed to in writing by an authorized officer of Nordfab, the payment terms hereunder and under each Order are NET 30. If the full purchase price is not paid by Buyer NET 30, then interest shall accrue at the rate of 1.5% per month. Buyer agrees that if Nordfab is required to bring suit to collect any sums due to Nordfab under these Terms, then Buyer shall be responsible for all costs and expenses incurred by Nordfab, including but not limited to Nordfab's reasonable attorneys' fees.

CLAIMS FOR SHORTAGES

Any claims for loss, breakage (obvious or concealed), or shortage are Buyer's sole responsibility and should be made to the carrier immediately. Nordfab will render Buyer reasonable assistance in securing satisfactory adjustment of such

ORDERING NOTES:

Unless specified, 3" through 24" is QF; over 24" is flanged. Data is subject to change without notice. Stainless steel components requiring flanges will be supplied with SS flanges unless otherwise specified. Stainless steel components are manufactured with standard gauges 304SS. [Call for quotation on SS 316 & 304SS heavy gauge prices] For special parts or items to be custom manufactured, call for quotation.

If you would like more information regarding our use of information you provide to us, please see our Privacy Policy on our website at nordfab.com/en-us/privacy-policy

claims. Any notice of shortages or other errors must be made in writing to Nordfab within 30 days after receipt of shipment. Failure to give such notice shall constitute unqualified acceptance of the Product and a waiver by Buyer of all claims against Nordfab for loss, breakage or shortage. Risk of loss for damage to Products sold under these Terms passes to Buyer when the carrier takes custody of any of the Products purchased under these Terms regardless of which party pays shipping costs.

LIMITATION OF LIABILITY

IN NO EVENT SHALL NORDFAB BE LIABLE FOR ANY SPECIAL, INDIRECT, INCIDENTAL, CONSEQUENTIAL OR COMPENSATORY DAMAGES OF ANY CHARACTER, INCLUDING, BUT NOT LIMITED TO, LOSS OF USE OF PRODUCTION FACILITIES OR EQUIPMENT, LOST REVENUES OR PROFITS, BUSINESS OR GOODWILL, PROPERTY DAMAGE, EXPENSES INCURRED IN RELIANCE ON NORDFAB'S PERFORMANCE HEREUNDER, AND/OR LOST PRODUCTION, WHETHER SUFFERED BY BUYER OR ANY THIRD PARTY, IN EACH CASE EVEN IF NORDFAB HAS BEEN ADVISED OR IS AWARE OF THE POSSIBILITY OF SUCH DAMAGES. UNDER NO CIRCUMSTANCES SHALL NORDFAB'S AGGREGATE LIABILITY ARISING OUT OF OR IN CONNECTION WITH THE SALE OF PRODUCTS, IN CONTRACT, TORT OR OTHERWISE, EXCEED THE PURCHASE PRICE OF THE PRODUCT TO WHICH SUCH LIABILITY RELATES. ANY ACTION FOR BREACH OF CONTRACT OR TORT MUST BE COMMENCED WITHIN ONE YEAR AFTER THE CAUSE OF ACTION HAS ACCRUED.

Nordfab specifically disclaims all liability for any and all costs, claims, demands, charges, expenses or other damages, either direct or indirect, incident to all property damages arising out of any cause of action based on strict liability.

INTELLECTUAL PROPERTY RIGHTS

The sale of Products or provision of services hereunder does not convey any express or implied license under any patent, copyright, trademark or other proprietary rights owned or controlled by Nordfab (beyond the use of the Product in the manner intended by Nordfab). Buyer agrees not to infringe, directly or indirectly, any patents of Nordfab or its affiliates through any combination or system incorporating a Product sold hereunder. In the event a Product is made or modified in accordance with Buyer's drawings, samples, manufacturing specifications, or the like, Buyer agrees to indemnify, defend, and hold Nordfab harmless from any and all damages, costs and expenses (including attorney's fees) related to any claim of patent infringement arising from such manufacture or modification. Buyer agrees, at Nordfab's sole discretion, to undertake the defense of such suit at its own expense.

COMPLIANCE WITH LAWS

Buyer shall comply with all laws and regulations applicable to the Products, including, but not limited to, all applicable import and export laws and regulations. Buyer has sole responsibility for obtaining any required export licenses. If the ultimate destination of the Products is outside of the United States, Buyer shall designate such country on its purchase order. In the event that Buyer purchases Products for export without so notifying Nordfab, Nordfab reserves the right to cancel the applicable order. Buyer will have sole liability and shall defend, indemnify and release Nordfab for any loss or damage (including without limitation, claims of governmental authorities) arising from the export from the United States or import into another country of such Products.

Without limiting the foregoing, Buyer represents and warrants to Nordfab that: (i) it is in compliance with all laws, ordinances, regulations and orders administered by the Office of Foreign Assets Control within the U.S. Department of the Treasury ("OFAC") or any other governmental authority imposing economic sanctions and trade embargoes ("Economic Sanctions Laws") against designated countries ("Embargoed Countries"), entities and persons (collectively, "Embargoed Targets"), and (ii) it is not itself an Embargoed Target or otherwise subject to any Economic Sanctions Law. Buyer shall comply with all Economic Sanctions Laws. Without limiting the generality of the foregoing, Buyer shall not (x) directly or indirectly export, re-export, transship, or otherwise deliver any Product (or any component or part thereof) to an Embargoed Target, or (y) broker, finance, or otherwise facilitate any transaction in violation of any Economic Sanctions Law.

ORDER CHANGES

Buyer may request changes to an Order (including the cancellation thereof) by sending an e-mail to Buyer's Inside Sales Account Manager and specifying in detail the requested changes (a "Change Order Request"). No Change Order Request will become effective until accepted or acknowledged in writing by Nordfab. In the event Nordfab accepts a Change Order Request, Buyer may be charged a change fee ranging from 10% to 100% of the total purchase price of the Products affected by such Change Order Request (the "Change Fee"), in each case as determined in Nordfab's sole discretion based on the production status and type of the affected Products and the nature of the Change Order Request. If Buyer submits a Change Order Request to delay the shipment of Products that have been produced and are ready for shipment, Buyer will be charged a storage fee of \$50 per day per box of affected Products (such storage fee together with the Change Fee, the "Change Order Fees"). All Change Order Fees will be in addition to the purchase price charged to Buyer under the applicable Order. Nordfab will invoice Buyer for any Change Order Fees, and Buyer shall pay such amounts in accordance with the payment terms set forth herein. Once an Order has shipped, Buyer may not submit a Change Order Request for such Order; provided that this section shall not affect Buyer's right to return Products as otherwise set forth herein.

RETURN MATERIAL AUTHORIZATION

To return Products to Nordfab, dealers must fill out an RMA Worksheet. The RMA can be requested from Nordfab's Sales Department. Each RMA must be filled out completely. Absolutely no shipments will be accepted by Nordfab without an RMA. Shipments without RMAs will be returned to shipper at shipper's expense. No RMA will be issued for any Order more than 90 days from the original ship date. If issued, an RMA is valid for 30 days from date of issue. Nordfab Products must be received at our designated return point factory within that 30 days in order for the dealer to receive credit. Only restockable items may be returned to Nordfab. Restockable items are identified in Nordfab's Product Reference and on Nordfab's website. All other items are considered custom or special order and are nonreturnable. Nordfab reserves the right to limit return quantities. All returned goods must be shipped freight prepaid. All Nordfab ductwork must be shipped vertically with rolled edge down to avoid incurring out-of-round damage during shipping. There is a 25% restocking charge for all returned goods. All components must arrive in "as-new" sellable condition. Damage and "white rust" occur over time at job sites, which may cause the items to not be sellable. Final determination of sell ability will be determined by Nordfab, at its sole discretion.

Take advantage of our online resources at www.nordfab.com:



WHERE does QUICK-FIT FIT?

Quick-Fit® Nordfab Quick-Fit is the ducting that's easy to install and easy to use. It's the ducting that's designed for the most demanding applications. It's the ducting that's designed for the most demanding applications.

Applications:

- Agriculture
- Automobile
- Building
- Chemical & food processing
- Food processing
- Manufacturing
- Metal casting
- Mining
- Plastics
- Process
- Shipbuilding
- Textiles
- Woodworking

Applications

Why Use Nordfab Ducting In Your Woodworking Shop?

3-Phase Application:

- **Phase 1:** Install ducting in your shop to collect dust from your machinery.
- **Phase 2:** Connect your ducting to a dust collector.
- **Phase 3:** Connect your ducting to a dust collector.

Applications Brochures

Nordfab Quick-Fit® Clamp-Together Ducting

- **Easy & fast to install:** No need for glue, sealant, or welding.
- **Ideal for dust, mist, and fume collection:** No need for glue, sealant, or welding.
- **Adaptable to your existing ductwork:** No need for glue, sealant, or welding.
- **Lower welded seams on duct pipe:** No need for glue, sealant, or welding.
- **Easy clean:** No need for glue, sealant, or welding.
- **Re-useable:** No need for glue, sealant, or welding.
- **Gas-tight, Stainless Steel, and aluminum:** No need for glue, sealant, or welding.
- **Nordfab provides:** No need for glue, sealant, or welding.

Clampdown Sheet

How to Design A Dust Collection System

QUICK-FIT Clamp-Together Ducting

- **Easy & fast to install:** No need for glue, sealant, or welding.
- **Adaptable to your existing ductwork:** No need for glue, sealant, or welding.
- **Lower welded seams on duct pipe:** No need for glue, sealant, or welding.
- **Easy clean:** No need for glue, sealant, or welding.
- **Re-useable:** No need for glue, sealant, or welding.
- **Gas-tight, Stainless Steel, and aluminum:** No need for glue, sealant, or welding.
- **Nordfab provides:** No need for glue, sealant, or welding.

How to Design a System

Nordfab QFS Sealed Duct System

Our original pipe hanger provides a very easy way to install and maintain your ducting system. It's the ducting that's designed for the most demanding applications.

QFS Sealed Duct System

The Right Hanger for Your Job

Manifold offers duct hangers in a variety of styles to fit a broad range of applications and duct locations.

- **Pipe Hanger HJ:** The "Right Hanger" for your job.
- **Grapple Hanger:** The "Right Hanger" for your job.
- **Clamp Hanger:** The "Right Hanger" for your job.
- **Shut Hanger:** The "Right Hanger" for your job.
- **Pipe Hanger:** The "Right Hanger" for your job.

Pipe Hangers

Nordfab Drawing Service Information Sheet (Rev #2)

Company Name: _____
 Address: _____
 Phone: _____
 Contact Person: _____
 Email: _____

General Information

1. Please indicate which this link line is located on the drawing page. (If you do not indicate, it will be assumed to be on the first page.)
2. Please indicate which this link line is located on the drawing page. (If you do not indicate, it will be assumed to be on the first page.)

Nordfab Drawing Service

Nordfab Ducting Helps You Make All The Right Connections

Manifold Specification Sheet

Please provide the following information when ordering a dust collection manifold:

1. Please indicate which this link line is located on the drawing page. (If you do not indicate, it will be assumed to be on the first page.)
2. Please indicate which this link line is located on the drawing page. (If you do not indicate, it will be assumed to be on the first page.)

Manifold Specification Sheet



Visit our website

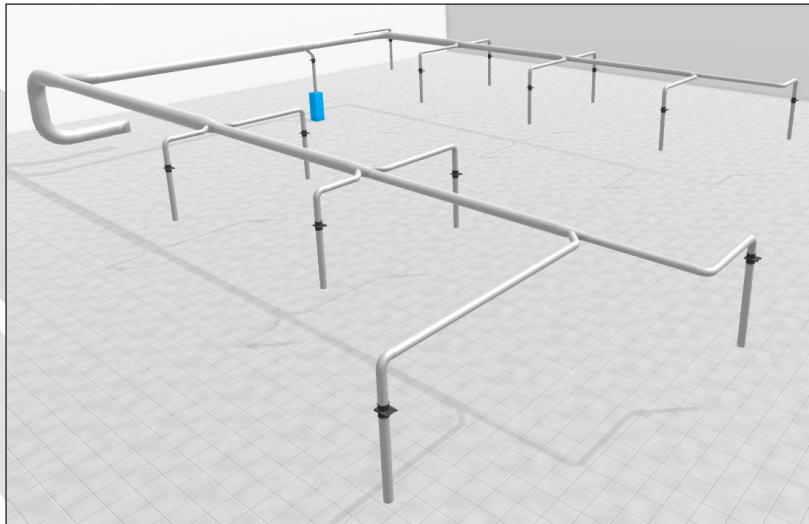

View a 3D design of your future duct installation. Contact Nordfab or your Nordfab Authorized Dealer to request a design.



During 2023, Nordfab has completed a 55,000 ft² addition to our QF Plant. The expansion includes a 1+ megawatt rooftop solar installation.



Heavy gauge ducting is manufactured in our XD Plant.

Your Local Ducting Expert:

Find your local Nordfab distributor or authorized dealer. Visit www.nordfab.com for more information.

All Quick-Fit® products are produced in an ISO-certified and process-oriented manufacturing environment.

ISO 9001 · ISO 14001